

ROLLING BEARINGS





A leading Taiwanese bearing company

TPI was established in 1966 and joint-ventured with a Japanese bearing company to develop self-own brand. The company's headquarter is located in Taipei, Taiwan.

Until now, we have four factories, two in Taiwan, one in Shanghai, and one in Indonesia, mainly producing deep groove ball bearings (DGBB) and angular contact ball bearings (ACBB).

Since 1966

Awarded Taiwan Excellence 2023

Awarded Taiwan Excellence 2021
&
2015

Established TPI Indonesia 2016

Awarded Top 100 Taiwan Brand 2011

Established TPI Shanghai 1999

Created the Brand **TPI**
BEARINGS 1983

Joint-Venture with NTN 1967

Established TPI Taiwan 1966



Technology
Precision
Innovation

Contents

Single-Row Deep Groove Ball Bearings	2
Bearing Designations	2
d 10~20mm	3
d 22~35mm	4
d 40~70mm	5
Special Dimensions of Bearings	6
Miniature and Extra Small Ball Bearings	8
Angular Contact Ball Bearings	10
Bearing Designations- Standard Series	10
Interchange	11
70C Series (15°)	12
70AD Series (25°)	13
70A Series (30°)	14
72C Series (15°)	15
72A Series (30°)	16
79C Series (15°)	17
79AD Series (25°)	18
BT Series (30°/40°)	19
Bearing Designations- High Speed Series	20
Interchange	21
HS CE1 Series (18°)	22
Precision Ball Screw Support Bearings	24
Bearing Designations	24
Interchange	25
BS Series	26
Double-Row Cylindrical Roller Bearings	28
Bearing Designations	28
d 30~130mm	29
Appendix I - Required Information for Deep Groove Ball Bearings Selection	30
Appendix II - Required Information for Spindle Bearings Selection	31
Appendix III - Dimensional Tolerance for Housing Shaft and Bore	32
Appendix IV - Tolerance for Bearings	34

Single-Row Deep Groove Ball Bearings

Bearing Designations

Supplementary Prefix Code

- F: Stainless steel bearings
- TS2: Dimension stabilized bearings for high temperature (to 160°C)
- TS3: Dimension stabilized bearings for high temperature (to 200°C)
- TS4: Dimension stabilized bearings for high temperature (to 200°C)
- CSB: Special heat treated long-life bearings
- ESB: Special heat treated and material, extra long-life bearings
- EC: Expansion compensating bearings
- AC: Creep preventing bearings

Seal or Shield

- LLB: Non-contact sealed type
- LLU: Contact sealed type
- LLH: Low torque sealed type
- ZZ: Shielded type

Accuracy

- (P0)
- P6
- P5
- P4
- P2

Diameter Symbol

- 8
- 9
- 0
- 2
- 3

Bearing Type

- Internal Clearance
- C2 (CN)
- C3
- C4
- CM
- NA

Bore Number

- (04 and up: multiply last two numbers by 5)
- 00: 10mm 04: 20mm
- 01: 12mm 05: 25mm
- 02: 15mm 12: 60mm
- 03: 17mm 20: 100mm

Lubrication

- 2AS
- L627
- 3ES
- 5K

TS2-6205ZZC3P5/2AS



Single-Row Deep Groove Ball Bearings | d 10~20mm

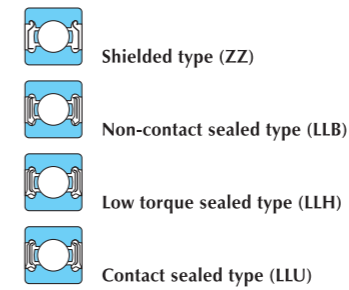
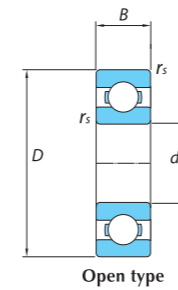

Equivalent bearing load dynamic
 $P_r = X F_r + Y F_a$

$\frac{F_a}{F_r}$	e	$\frac{F_a}{F_r} \leq e$		$\frac{F_a}{F_r} > e$	
		X	Y	X	Y
0.010	0.18				2.46
0.020	0.20				2.14
0.040	0.24				1.83
0.070	0.27				1.61
0.10	0.29				1.48
0.15	0.32	1	0	0.56	1.35
0.20	0.35				1.25
0.30	0.38				1.13
0.40	0.41				1.05
0.50	0.44				1.00

static
 $P_{or} = 0.6 F_r + 0.5 F_a$ When $P_{or} < F_r$ use $P_{or} = F_r$

Boundary Dimensions(mm)				Basic Load Ratings(N)		Limiting Speeds (rpm)				Bearing Numbers Type						
d	D	B	$r_{s \min}$	Dynamic	Static	Open Z, ZZ	Grease	Oil	Open	Shield	Seal Non-	Low Torque	Seal Contact	Snap Ring	Snap Ring	
				C_r	C_{or}	LB, LLB	LLH	Open Z, LB	Type	ZZ	Contact LLB	Type LLH	LLU	Groove	Ring	
10	19	5	0.3	1830	925	32000	-	24000	38000	6800	ZZ	LLB	-	LLU	-	
22	6	0.3	2700	1270	30000	-	21000	36000	6900	ZZ	LLB	-	LLU	N	NR	
26	8	0.3	4550	1960	29000	25000	20700	34000	6000	ZZ	LLB	LLH	LLU	N	NR	
30	9	0.6	5100	2390	25000	21000	18000	30000	6200	ZZ	LLB	LLH	LLU	N	NR	
35	11	0.6	8200	3500	23000	20000	16000	27000	6300	ZZ	LLB	LLH	LLU	N	NR	
12	21	5	0.3	1920	1040	29000	-	20000	35000	6801	ZZ	LLB	-	LLU	-	
24	6	0.3	2890	1460	27000	-	19000	32000	6901	ZZ	LLB	-	LLU	N	NR	
28	7	0.3	5100	2390	26000	-	-	30000	16001	-	-	-	-	-	-	
28	8	0.3	5100	2390	26000	21000	18000	30000	6001	ZZ	LLB	LLH	LLU	N	NR	
32	10	0.6	6100	2750	22000	20000	16000	26000	6201	ZZ	LLB	LLH	LLU	N	NR	
37	12	1	9700	4200	20000	19000	15000	24000	6301	ZZ	LLB	LLH	LLU	N	NR	
15	24	5	0.3	2080	1260	26000	-	17000	31000	6802	ZZ	LLB	-	LLU	-	
28	7	0.3	3650	2000	24000	-	16000	28000	6902	ZZ	LLB	-	LLU	N	NR	
32	8	0.3	5600	2830	22000	-	-	26000	16002	-	-	-	-	-	-	
32	9	0.3	5600	2830	22000	18000	15000	26000	6002	ZZ	LLB	LLH	LLU	N	NR	
35	11	0.6	7750	3600	19000	18000	15000	23000	6202	ZZ	LLB	LLH	LLU	N	NR	
42	13	1	11400	5450	17000	15000	12000	21000	6302	ZZ	LLB	LLH	LLU	N	NR	
17	26	5	0.3	2230	1460	24000	-	15000	28000	6803	ZZ	LLB	-	LLU	-	
30	7	0.3	4650	2580	22000	-	14000	26000	6903	ZZ	LLB	-	LLU	N	NR	
35	8	0.3	6800	3350	20000	-	-	24000	16003	-	-	-	-	-	-	
35	10	0.3	6800	3350	20000	16000	14000	24000	6003	ZZ	LLB	LLH	LLU	N	NR	
40	12	0.6	9600	4600	18000	15000	12000	21000	6203	ZZ	LLB	LLH	LLU	N	NR	
47	14	1	13500	6550	16000	14000	11000	19000	6303	ZZ	LLB	LLH	LLU	N	NR	
20	32	7	0.3	4000	2470	21000	-	13000	25000	6804	ZZ	LLB	-	LLU	N	NR
37	9	0.3	6400	3700	19000	-	12000	23000	6904	ZZ	LLB	-	LLU	N	NR	
42	8	0.3	7900	4500	18000	-	-	21000	16004	-	-	-	-	-	-	
42	12	0.6	9400	5050	18000	13000	11000	21000	6004	ZZ	LLB	LLH	LLU	N	NR	
47	14	1	12800	6650	16000	12000	10000	18000	6204	ZZ	LLB	LLH	LLU	N	NR	
52	15	1.1	15900	7900	14000	12000	10000	17000	6304	ZZ	LLB	LLH	LLU	N	NR	

Single-Row Deep Groove Ball Bearings | d 22~35mm

Shielded type (ZZ)
Non-contact sealed type (LLB)
Low torque sealed type (LLH)
Contact sealed type (LLU)

Open type

Equivalent bearing load dynamic
 $P_r = X F_r + Y F_a$

$\frac{F_a}{C_{or}}$	e	$\frac{F_a}{F_r} \leq e$		$\frac{F_a}{F_r} > e$	
		X	Y	X	Y
0.010	0.18			2.46	
0.020	0.20			2.14	
0.040	0.24			1.83	
0.070	0.27			1.61	
0.10	0.29	1	0	1.48	0.56
0.15	0.32			1.35	
0.20	0.35			1.25	
0.30	0.38			1.13	
0.40	0.41			1.05	
0.50	0.44			1.00	

static
 $P_{or} = 0.6 F_r + 0.5 F_a$ When $P_{or} < F_r$ use $P_{or} = F_r$

Boundary Dimensions(mm)				Basic Load Ratings(N)		Limiting Speeds (rpm)				Bearing Numbers Type						
d	D	B	$r_{s \min}$	Dynamic C_r	Static C_{or}	Open Z, ZZ LB, LLB	Grease LLH	Oil LU, LLU	Oil Open Z, LB	Open Type	Shield ZZ	Seal Non- Contact LLB	Low Torque Type LLH	Seal Contact LLU	Snap Ring Groove	Snap Ring
22	44	12	0.6	9400	5050	17000	13000	10000	20000	60/22	ZZ	LLB	LLH	LLU	N	NR
50	14	1		12900	6800	14000	12000	9700	17000	62/22	ZZ	LLB	LLH	LLU	N	NR
56	16	1.1		18400	9250	13000	11000	9200	15000	63/22	ZZ	LLB	LLH	LLU	N	NR
25	37	7	0.3	4300	2950	18000	-	10000	21000	6805	ZZ	LLB	-	LLU	N	NR
42	9	0.3		7050	4550	16000	-	9800	19000	6905	ZZ	LLB	-	LLU	N	NR
47	8	0.3		8350	5100	15000	-	-	18000	16005	-	-	-	-	-	-
47	12	0.6		10100	5850	15000	11000	9400	18000	6005	ZZ	LLB	LLH	LLU	N	NR
52	15	1		14000	7850	13000	11000	8900	15000	6205	ZZ	LLB	LLH	LLU	N	NR
62	17	1.1		21200	10900	12000	9700	8100	14000	6305	ZZ	LLB	LLH	LLU	N	NR
80	21	1.5		34500	17500	10000	-	-	12000	6405	-	-	-	-	-	-
28	52	12	0.6	12500	7400	14000	10000	8400	16000	60/28	ZZ	LLB	LLH	LLU	N	NR
58	16	1		17900	9750	12000	9700	8100	14000	62/28	ZZ	LLB	LLH	LLU	N	NR
68	18	1.1		26700	14000	11000	8900	7400	13000	63/28	ZZ	LLB	LLH	LLU	N	NR
30	42	7	0.3	4700	3650	15000	-	8800	18000	6806	ZZ	LLB	-	LLU	N	NR
47	9	0.3		7250	5000	14000	-	8400	17000	6906	ZZ	LLB	-	LLU	N	NR
55	9	0.3		11200	7350	13000	-	-	15000	16006	-	-	-	-	-	-
55	13	1		13200	8300	13000	9200	7700	15000	6006	ZZ	LLB	LLH	LLU	N	NR
62	16	1		19500	11300	11000	8800	7300	13000	6206	ZZ	LLB	LLH	LLU	N	NR
72	19	1.1		26700	15000	10000	7900	6600	12000	6306	ZZ	LLB	LLH	LLU	N	NR
32	58	13	1	11800	8050	12000	8700	7200	15000	60/32	ZZ	LLB	LLH	LLU	N	NR
65	17	1		20700	11600	11000	8400	7100	12000	62/32	ZZ	LLB	LLH	LLU	N	NR
75	20	1.1		29800	16900	9500	7700	6500	11000	63/32	ZZ	LLB	LLH	LLU	N	NR
35	47	7	0.3	4900	4050	13000	-	-	16000	6807	ZZ	LLB	-	LLU	N	NR
55	10	0.6		9550	6850	12000	-	7100	15000	6907	ZZ	LLB	-	LLU	N	NR
62	9	0.3		11700	8200	12000	-	-	14000	16007	-	-	-	-	-	-
62	14	1		16000	10300	12000	8200	6800	14000	6007	ZZ	LLB	LLH	LLU	N	NR
72	17	1.1		25700	15300	9800	7600	6300	11000	6207	ZZ	LLB	LLH	LLU	N	NR
80	21	1.5		33500	19100	8800	7300	6000	10000	6307	ZZ	LLB	LLH	LLU	N	NR

Single-Row Deep Groove Ball Bearings | d 40~70mm

Shielded type (ZZ)
Non-contact sealed type (LLB)
Low torque sealed type (LLH)
Contact sealed type (LLU)

Open type

Equivalent bearing load dynamic
 $P_r = X F_r + Y F_a$

$\frac{F_a}{C_{or}}$	e	$\frac{F_a}{F_r} \leq e$		$\frac{F_a}{F_r} > e$	
		X	Y	X	Y
0.010	0.18			2.46	
0.020	0.20			2.14	
0.040	0.24			1.83	
0.070	0.27			1.61	
0.10	0.29	1	0	1.48	0.56
0.15	0.32			1.35	
0.20	0.35			1.25	
0.30	0.38			1.13	
0.40	0.41			1.05	
0.50	0.44			1.00	

static
 $P_{or} = 0.6 F_r + 0.5 F_a$ When $P_{or} < F_r$ use $P_{or} = F_r$

Boundary Dimensions(mm)				Basic Load Ratings(N)		Limiting Speeds (rpm)				Bearing Numbers Type						
d	D	B	$r_{s \min}$	Dynamic C_r	Static C_{or}	Open Z, ZZ LB, LLB	Grease LLH	Oil LU, LLU	Oil Open Z, LB	Open Type	Shield ZZ	Seal Non- Contact LLB	Low Torque Type LLH	Seal Contact LLU	Snap Ring Groove	Snap Ring
40	52	7	0.3	5100	4400	12000	-	-	14000	6808	ZZ	LLB	-	LLU	N	NR
62	12	0.6		12200	8900	11000	-	6300	13000	6908	ZZ	LLB	-	LLU	N	NR
68	9	0.3		12600	9650	10000	-	-	12000	16008	-	-	-	-	-	-
68	15	1		16800	11500	10000	7300	6100	12000	6008	ZZ	LLB	LLH	LLU	N	NR
80	18	1.1		29100	17800	8700	6700	5600	10000	6208	ZZ	LLB	LLH	LLU	N	NR
90	23	1.5		40500	24000	7800	6400	5300	9200	6308	ZZ	LLB	LLH	LLU	N	NR
45	58	7	0.3	5350	4950	11000	-	5900	12000	6809	ZZ	LLB	-	LLU	N	NR
68	12	0.6		13100	10400	9800	-	5600	12000	6909	ZZ	LLB	-	LLU	N	NR
75	10	0.6		12900	10500	9200	-	-	11000	16009	-	-	-	-	-	-
75	16	1		21000	15100	9200	6500	5400	11000	6009	ZZ	LLB	LLH	LLU	N	NR
85	19	1.1		32500	20400	7800	6200	5200	9200	6209	ZZ	LLB	LLH	LLU	N	NR
100	25	1.5		53000	32000	7000	5600	4700	8200	6309	ZZ	LLB	LLH	LLU	N	NR
50	65	7	0.3	6600	6100	9600	-	5300	11000	6810	ZZ	LLB	-	LLU	N	NR
72	12	0.6		13400	11200	8900	-	5100	11000	6910	ZZ	LLB	-	LLU	N	NR
80	10	0.6		13200	11300	8400	-	-	9800	16010	-	-	-	-	-	-
80	16	1		21800	16600	8400	6000	5000	9800	6010	ZZ	LLB	LLH	LLU	N	NR
90	20	1.1		35000	23200	7100	5700	4700	8300	6210	ZZ	LLB	LLH	LLU	N	NR
110	27	2		62000	38500	6400	5000	4200	7500	6310	ZZ	LLB	LLH	LLU	N	NR
55	72	9	0.3	8800	8100	8700	-	4800	10000	6811	ZZ	LLB	-	LLU	N	NR
80	13	1		16000	13300	8200	-	4600	9600	6911	ZZ	LLB	-	LLU	N	NR
90	11	0.6		18600	15300	7700	-	-	9000	16011	-	-	-	-	-	-
90	18	1.1		28300	21200	7700	-	4500	9000	6011	ZZ	LLB	-	LLU	N	NR
100	21	1.5		43500	29200	6400	-	4300	7600	6211	ZZ	LLB	-	LLU	N	NR
120	29	2		71500	45000	5800	-	3900	6800	6311	ZZ	LLB	-	LLU	N	NR
60	78	10	0.3	11500	10600	8000	-	4400	9400	6812	ZZ	LLB	-	LLU	N	NR
85	13	1		16400	14300	7600	-	4300	8900	6912	ZZ	LLB	-	LLU	N	NR
95	11	0.6		20000	17500	7000	-	-	8300	16012	-	-	-	-	-	-
95	18	1.1		29500	23200	7000	-	4100	8300	6012	ZZ	LLB	-	LLU	N	NR
110	22	1.5		52500	36000	6000	-	3800	7000	6212	ZZ	LLB	-	LLU	N	NR
130	31	2.1		82000	52000	5400	-	3600	6300	6312	ZZ	LLB	-	LLU	N	NR
65	140	33	2.1	92500	60000	4900	-	-	5800	6313	-	-	-	-	-	-
70	150	35	3	104000	68000	4100	-	-	4800	6314	-	-	-	-	-	-

Single-Row Deep Groove Ball Bearings | Special Dimensions of Bearings

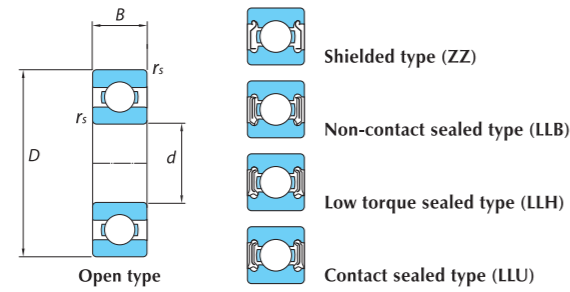

Equivalent bearing load
dynamic
 $P_r = X F_r + Y F_a$

$\frac{F_a}{C_{or}}$	e	$\frac{F_a}{F_r} \leq e$		$\frac{F_a}{F_r} > e$	
		X	Y	X	Y
0.010	0.18			2.46	
0.020	0.20			2.14	
0.040	0.24			1.83	
0.070	0.27	1	0	1.61	
0.10	0.29			1.48	
0.15	0.32			1.35	
0.20	0.35			1.25	
0.30	0.38			1.13	

static
 $P_{or} = 0.6 F_r + 0.5 F_a$ When $P_{or} < F_r$ use $P_{or} = F_r$

Single-Row Deep Groove Ball Bearings

Boundary Dimensions(mm)				Basic Load Ratings(N)		Limiting Speeds (rpm)		Bearing Numbers		
d	D	B	$r_{s \text{ min}}$	C_r	C_{or}	Grease	Oil	Open	Non Contact Seal Shield ZZ	Contact Seal LLU
12	32	10	0.6	6100	2750	22000	26000	AC-6201	AC-6201ZZ	AC-6201LLU
15	35	11	0.6	7750	3600	19000	23000	AC-6202	AC-6202ZZ	AC-6202LLU
17	40	12	0.6	9600	4600	18000	21000	AC-6203	AC-6203ZZ	AC-6203LLU
20	47	14	1.0	12800	6650	16000	18000	-	AC-6204 LLB	AC-6204 LLU
25	52	15	1.0	14000	7850	13000	15000	-	AC-6205ZZ	-
30	55	13	1.0	13200	8300	13000	15000	-	AC-6006ZZ	-
8	23	14	0.3	3950	1540	22000	26000	EC1-SC8A37	-	-
8	22	7	0.3	3350	1400	32000	37000	EC-608	EC-608ZZ	-
9	26	8	0.3	4550	1960	30000	35000	EC-629	EC-629ZZ	EC-629LLU
10	26	8	0.3	4550	1960	29000	34000	EC-6000	EC-6000ZZ	EC-6000LLU
12	28	8	0.3	5100	2390	26000	30000	-	EC1-6001ZZ	-
15	32	9	0.3	5600	2830	22000	26000	EC-6002	EC-6002ZZ	EC-6002LLU
15	35	11	0.6	7750	3600	19000	23000	EC1-6202	EC1-6202LLB	-
9.525	22.225	5.557	0.41	3300	1400	31000	37000	EE3	-	-
9.525	22.225	7.142	0.41	3300	1400	31000	37000	-	R6ZZ	R6LLU
12.7	28.575	6.35	0.41	5100	2390	25000	29000	EE4	-	-
12.7	28.575	7.938	0.41	5100	2390	25000	29000	R8U	R8ZZ	R8LLU
30	62	16	1.0	24900	16300	10000	12000	BL206	-	-
35	72	17	1.1	33000	22100	8800	10000	BL207	-	-
7	18	6	0.2	2240	910	34000	40000	-	SC727ZZ	-
8	18	6	0.2	2240	910	34000	40000	-	SC8A96ZZ	-
10	26	8	0.3	4590	1980	29000	34000	-	SC0039ZZ	-
10	30	8	0.6	5100	2390	25000	30000	SC00T50	-	-
11.087	30	9	0.6	5100	2390	18000	30000	-	-	SC0117LLU
14	26	7	0.3	3430	1795	26000	31000	-	SC02T01LLB	-
15	42	11.5	0.6	11400	5450	17000	21000	SC0284	-	-
15	35	8.5	0.6	7750	3600	19000	23000	SC02A17	-	-
15	35	13	0.6	7760	3610	19000	23000	-	-	SC02A51LLU

Boundary Dimensions(mm)				Basic Load Ratings(N)		Limiting Speeds (rpm)		Bearing Numbers		
d	D	B	$r_{s \text{ min}}$	C_r	C_{or}	Grease	Oil	Open	Non Contact Seal Shield ZZ	Contact Seal LLU
15.875	34.925	11	0.6	7750	3600	15000	23000	-	SC0217ZZ	SC0217LLU
15.875	34.925	11.112	0.6	7750	3600	15000	23000	-	SC0228LLB	SC0228LLU
15.875	34.925	11	0.6	7750	3600	15000	23000	-	-	SC02A47LLU
17	42	13	0.6	11400	5200	18000	21000	SC03A39	-	-
17	42	12	0.6	11400	5200	18000	21000	SC0345	-	SC0345LLU
17	40	14	0.6	9600	4600	18000	21000	-	-	SC03T01LLU
17	46	14	0.6	13500	6550	11000	19000	-	-	SC03T52LLU
17	52	16	1.0	16000	7940	11000	19000	-	-	SC03T50LLU
18	30	7	0.3	4600	2620	22000	26000	-	-	SC03T02LLB
19.05	45.225	15.494	1.0	13500	6550	16000	19000	SC04B09	-	-
19.06	45.224	15.494	1.0	12800	6550	16000	19000	-	-	SC0440LLU
20	47	12	1.0	12800	6650	16000	18000	SC04A31	-	-
20	47	12	1.0	10100	5750	14000	17000	SC04A34	-	-
20	52	12	1.0	10100	5750	14000	17000	SC04A47	-	-
20	52	12	1.0	12800	6650	16000	18000	SC04A50	-	-
22	56	15	1.1	20700	10400	13000	15000	SC04A86	-	-
22	56	15	1.5	20700	10400	13000	15000	SC632201	-	-
25	52	13	1.0	14000	7850	13000	15000	SC05T52	-	-
25	52	15	1.0	14000	7850	13000	15000	-	-	SC05T03LLB
25	52	15	1.0	14000	7850	13000	15000	SC05T51	-	-
25	56	12	0.6	14000	7850	13000	15000	SC05A97	-	-
25	62	12	0.6	16700	9600	12000	14000	SC0563	-	-
28	72	18	1.5	19500	11300	11000	13000	SC06T02	-	-
35	72	14	1.0	25700	15300	9800	11000	SC07B37	-	-
6	19	6.6	0.3	2340	885	34000	40000	-	SX6A54ZZ	-
12	32	10.8	0.6	6100	2750	22000	26000	SX01A36	-	-
12	32	16	0.6	6100	2750	22000	26000	SX01T50	-	-
15	35	11	0.6	7750	3600	19000	23000	-	SX02A26ZZ	-
27	47	8	0.3	10100	5850	15000	18000	SX05A81	-	-
15.875	34.925	11	0.6	7750	3600	15000		99502		

Angular Contact Ball Bearings

Bearing Designations Standard Series

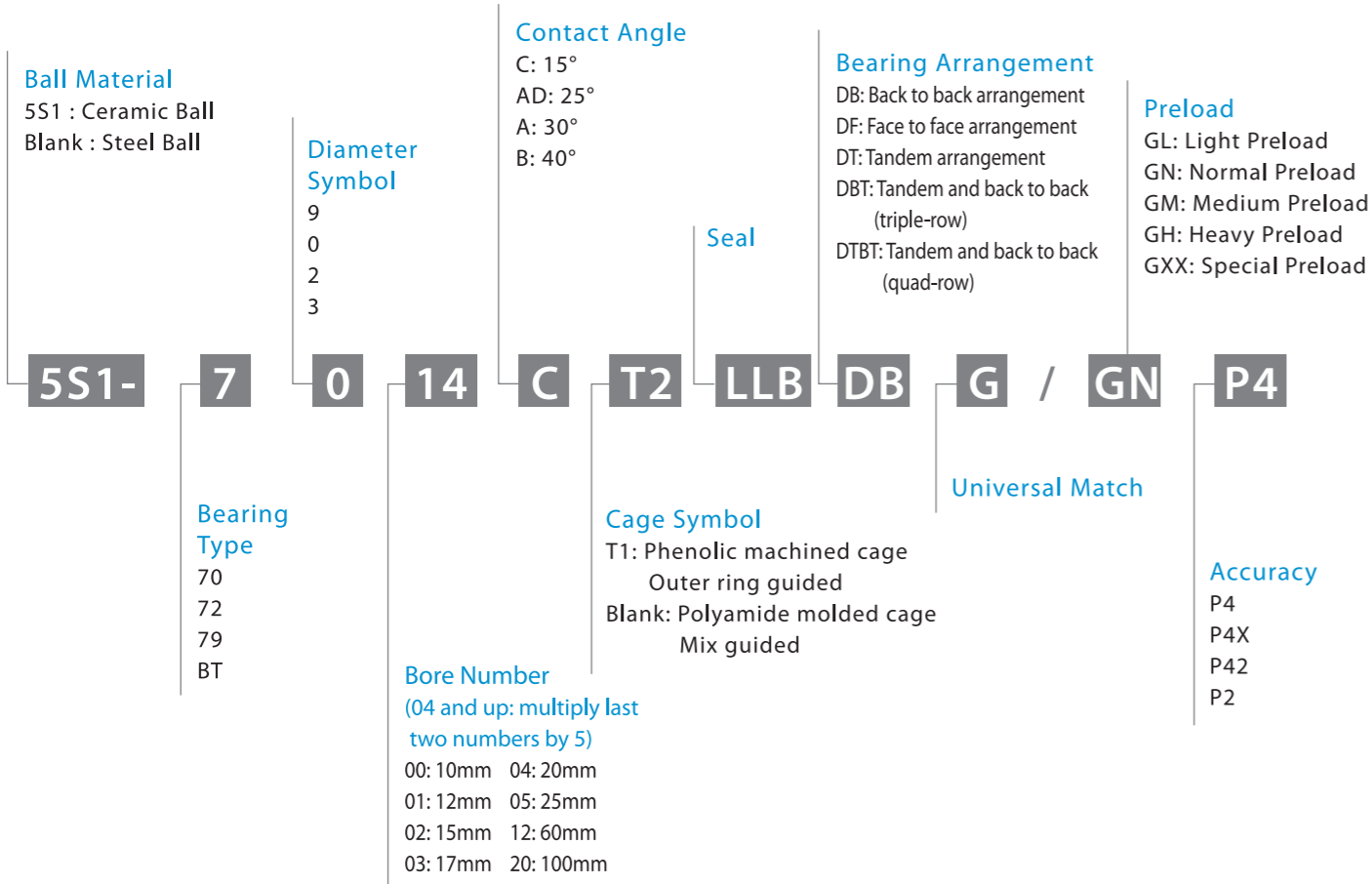
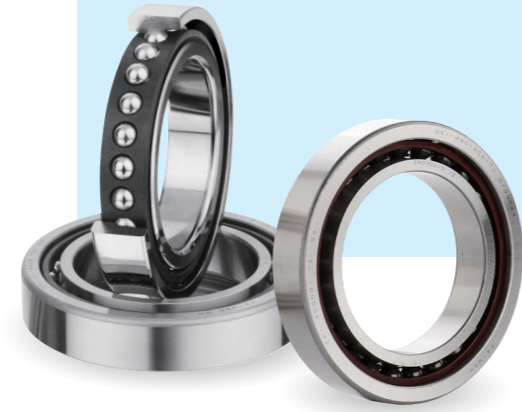

Interchange

Description	Interchange							
	TPI	NSK	SKF	FAG	BARDEN	NTN	KOYO	GMN
Part No.	79XX	79XX	719XX	719XX	19XXH	79XX	79XX	S69XX
	70XX	70XX	70XX	70XX	1XXH	70XX	70XX	S60XX
	72XX	72XX	72XX	72XX	2XXH	72XX	72XX	S62XX
Series	Standard	7	7	7	H	7	7	S
Ceramic Ball		5S1	SN24	HC	HCB	C	5S	3NC
Contact Angle	15°	C	C	CD	C	Blank	C	C
	25°	AD	A5, BER	ACD	E	—	AD	—
	30°	A	A	A	—	—	(A)	(A)
	40°	B	—	B	—	—	—	—
Cage	Phenolic Machined Cage ¹⁾	T1	TR	—	T	TA	T1	FT
	Outer ring guided	Blank	TYN	TN, TN9	—	TMT	T2	FG
	Polyamide Molded Cage Mix guided	Blank	TYN	TN, TN9	—	TMT	T2	FG
Seal	LLB	V1V	S	2RSD	—	LLB	—	2RZ
	DB	DB	DB	DB	DB	DB	DB	DB
	DF	DF	DF	DF	DF	DF	DF	DF
	DT	DT	DT	DT	DT	DT	DT	DT
	DBT	DBD	TBT	—	—	DBT	DBD	TBT
	DFT	DFD	TFT	—	—	DFT	DFD	TFT
	DTBT	DBB	QBC	—	—	DTBT	DBB	QBC
Single Universal Match	G	SU	G	U	DS	G	G	U
Duplex Universal Match	D2G	DU	DG	DU	—	GD2	—	—
Preload	Light Preload	GL	EL	A	—	—	GL	—
	Normal Preload	GN	L	B	L	L	GN	L
	Medium Preload	GM	M	C	M	M	GM	M
	Heavy Preload	GH	H	—	H	H	—	H
Precision Grade	JIS 4 / ABEC 7	P4	P4	P4	—	P4	P4	P4
	JIS 4 Special Tolerance	P4X ²⁾	P4Y	—	—	—	—	K5
	JIS 4 Special Tolerance	P42 ³⁾	P3	P4A	P4S	—	P42	—
	JIS 2 / ABEC 9	P2	P2	PA9A	—	—	P2	P2

- 1) Phenolic Machined Cage: Available on request.
- 2) P4X: Special bore and outer diameter. Others are JIS 4.
- 3) P42: JIS 4 dimensional tolerances and JIS 2 running accuracy.

This interchange table is designed to assist in identifying equivalent models for TPI's products. However, as other manufacturers may frequently update their bearing designations, we assume no liability for any inaccuracies in the information provided in this table.

Applications

Machine tool spindles

Features

1. Well-developed 70 and 72 series to meet wide range of demands from customers.
2. P4 grade precision and universal match design for all series to meet all kinds of bearing arrangement requests.
3. Optimizing inner design of the bearings, lower the temperature rises and increase the limiting speed.

Angular Contact Ball Bearings 70C Series | d 10~100mm

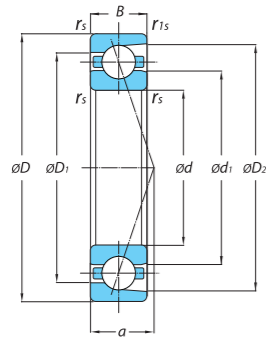
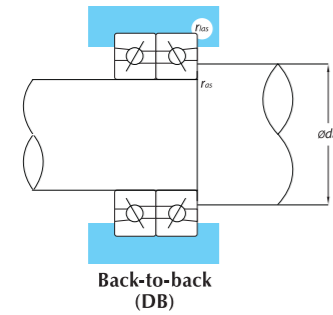

Table 1.1 Value of Factors X and Y

Normal Contact Angle	i ₀ F _a * / C _{or}	e	Single, DT				DB or DF											
			F _a /F _r ≤ e		F _a /F _r > e		F _a /F _r ≤ e		F _a /F _r > e									
			X	Y	X	Y	X	Y	X	Y								
15	0.178	0.38			1.47					2.39								
	0.357	0.4			1.4					2.28								
	0.714	0.43			1.3					2.11								
	1.07	0.46	1	0	0.14	1.23	1	1.38	0.72	2								
	1.43	0.47									1.19	0.34	1.93					
	2.14	0.5									1.12	0.26	1.82					
	3.57	0.55									1.02	1.14	1.66					
	5.35	0.56									1	1.12	1.63					
	18	0.57									1	0	0.43	1	1	1.09	0.7	1.63
	25	0.68									1	0	0.41	0.87	1	0.92	1.67	1.41
30	0.8	1									0	0.39	0.76	1	0.78	1.63	1.24	
40	1.14	1									0	0.35	0.57	1	0.55	0.57	0.93	
50	1.49											0.73	1	1.37	0.57	0.73		
55	1.79			0.81	1	1.6	0.56	0.81										
60	2.17			0.92	1	1.9	0.55	0.92										

For i, use 2 for DB, DF and 1 for DT



Back-to-back (DB)

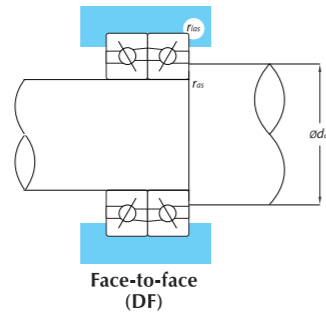

Face-to-face (DF)

Table 2.1 Static Equivalent Load Po=XoFr+YoFa

Contact Angle	Single, DT		DB or DF	
	Xo	Yo	Xo	Yo
15	0.5	0.46	1	0.92
18	0.5	0.42	1	0.84
25	0.5	0.38	1	0.76
30	0.5	0.33	1	0.66
40	0.5	0.26	1	0.52

Angular Contact Ball Bearings 70AD Series | d 10~100mm

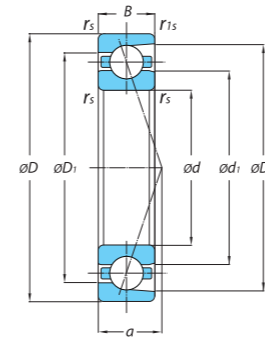
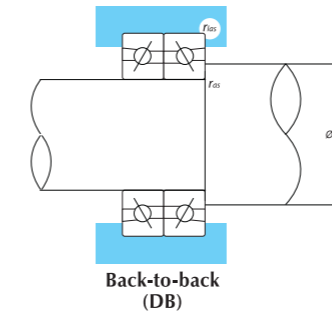

Table 1.1 Value of Factors X and Y

Normal Contact Angle	i ₀ F _a * / C _{or}	e	Single, DT				DB or DF											
			F _a /F _r ≤ e		F _a /F _r > e		F _a /F _r ≤ e		F _a /F _r > e									
			X	Y	X	Y	X	Y	X	Y								
15	0.178	0.38			1.47					2.39								
	0.357	0.4			1.4					2.28								
	0.714	0.43			1.3					2.11								
	1.07	0.46	1	0	0.14	1.23	1	1.38	0.72	2								
	1.43	0.47									1.19	0.34	1.93					
	2.14	0.5									1.12	0.26	1.82					
	3.57	0.55									1.02	1.14	1.66					
	5.35	0.56									1	1.12	1.63					
	18	0.57									1	0	0.43	1	1	1.09	0.7	1.63
	25	0.68									1	0	0.41	0.87	1	0.92	1.67	1.41
30	0.8	1									0	0.39	0.76	1	0.78	1.63	1.24	
40	1.14	1									0	0.35	0.57	1	0.55	0.57	0.93	
50	1.49											0.73	1	1.37	0.57	0.73		
55	1.79			0.81	1	1.6	0.56	0.81										
60	2.17			0.92	1	1.9	0.55	0.92										

For i, use 2 for DB, DF and 1 for DT



Back-to-back (DB)

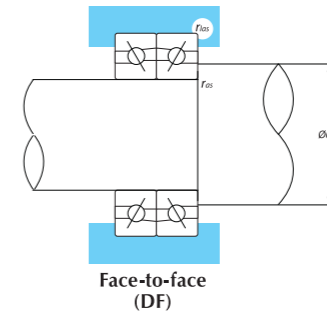

Face-to-face (DF)

Table 2.1 Static Equivalent Load Po=XoFr+YoFa

Contact Angle	Single, DT		DB or DF	
	Xo	Yo	Xo	Yo
15	0.5	0.46	1	0.92
18	0.5	0.42	1	0.84
25	0.5	0.38	1	0.76
30	0.5	0.33	1	0.66
40	0.5	0.26	1	0.52

Boundary Dimensions (mm)					Basic Load Ratings				Bearing Numbers Type	Load Center (mm)	Limiting Speeds n _l (min ⁻¹)	
d	D	B	r _{s min}	r _{1s min}	Dynamic C _r		Static C _{or}				a	Grease
10	26	8	0.3	0.15	5.30	540	2.45	250	7000C	6.0	63900	97300
12	28	8	0.3	0.15	5.40	555	2.63	269	7001C	6.5	57500	87500
15	32	9	0.3	0.15	6.20	635	3.35	345	7002C	7.5	49000	74500
17	35	10	0.3	0.15	6.55	670	3.80	390	7003C	8.5	44300	67400
20	42	12	0.6	0.3	11.1	1130	6.55	670	7004C	10.0	37100	56500
25	47	12	0.6	0.3	11.7	1190	7.40	755	7005C	11.0	32000	48700
30	55	13	1.0	0.6	15.1	1540	10.3	1050	7006C	12.0	27100	41200
35	62	14	1.0	0.6	19.1	1950	13.7	1400	7007C	13.5	23800	36100
40	68	15	1.0	0.6	20.6	2100	15.9	1620	7008C	15.0	21300	32500
45	75	16	1.0	0.6	24.4	2490	19.3	1970	7009C	16.0	19200	29200
50	80	16	1.0	0.6	26.0	2650	21.9	2230	7010C	16.0	17700	27000
55	90	18	1.1	0.6	34.0	3500	28.6	2900	7011C	19.0	15900	24200
60	95	18	1.1	0.6	35.0	3600	30.0	3100	7012C	19.5	14900	22600
65	100	18	1.1	0.6	37.0	3800	34.0	3500	7013C	20.0	14000	21300
70	110	20	1.1	0.6	47.0	4800	43.0	4400	7014C	22.0	12800	19500
75	115	20	1.1	0.6	48.0	4900	45.5	4650	7015C	23.0	12200	18500
80	125	22	1.1	0.6	58.5	6000	55.5	5650	7016C	25.0	11300	17100
85	130	22	1.1	0.6	60.0	6150	58.5	6000	7017C	25.0	10700	16300
90	140	24	1.5	1.1	71.5	7300	69.0	7000	7018C	27.0	10000	15300
95	145	24	1.5	1.1	73.5	7500	73.0	7450	7019C	28.0	9600	14600
100	150	24	1.5	1.1	75.5	7700	77.0	7900	7020C	29.0	9200	14000

Boundary Dimensions (mm)					Basic Load Ratings				Bearing Numbers Type	Load Center (mm)	Limiting Speeds n _l (min ⁻¹)	
d	D	B	r _{s min}	r _{1s min}	Dynamic C _r		Static C _{or}				a	Grease
10	26	8	0.3	0.15	5.10	520	2.41	246	7000AD	8.2	55000	84700
12	28	8	0.3	0.15	5.20	530	2.53	258	7001AD	8.8	49500	76100
15	32	9	0.3	0.15	5.95	605	3.20	330	7002AD	10.0	42100	64800
17	35	10	0.3	0.15	6.30	640	3.60	370	7003AD	11.1	38100	58600
20	42	12	0.6	0.3	10.5	1080	6.25	640	7004AD	12.2	31900	49200
25	47	12	0.6	0.3	11.0	1130	7.05	720	7005AD	14.4	27500	42400
30	55	13	1.0	0.6	14.4	1470	9.80	1000	7006AD	15.9	23300	35800
35	62	14	1.0	0.6	18.2	1860	13.0	1330	7007AD	17.8	20500	31400
40	68	15	1.0	0.6	19.5	1990	15.1	1540	7008AD	19.6	18300	28300
45	75	16	1.0	0.6	23.0	2350	18.2	1860	7009AD	21.5	16500	25400
50	80	16	1.0	0.6	24.6	2510	20.7	2120	7010AD	23.2	15200	23500
55	90	18	1.1	0.6	32.0	3300	27.1	2770	7011AD	25.9	13700	21100
60	95	18	1.1	0.6	33.0	3350	29.1	2970	7012AD	27.1	12800	19700
65	100	18	1.1	0.6	35.0	3550	32.0	3300	7013AD	28.2	12000	18500
70	110	20	1.1	0.6	44.0	4500	40.5	4150	7014AD	31.0	11000	17000
75	115	20	1.1	0.6	45.0	4600	43.0	4400	7015AD	22.1	10500	16100
80	125	22	1.1	0.6	55.5	5650	52.0	5350	7016AD	34.9	9700	14900
85	130	22	1.1	0.6	56.5	5800	55.5	5650	7017AD	36.1	9200	14200
90	140	24	1.5	1.1	67.5	6900	65.5	6650	7018AD	38.8	8600	13300
95	145	24	1.5	1.1	69.5	7050	69.0	7050	7019AD	40.0	8300	12700
100	150	24	1.5	1.1	71.0	7250	73.0	7450	7020AD	41.1	7900	12200

Angular Contact Ball Bearings 70A Series | d 10~50mm

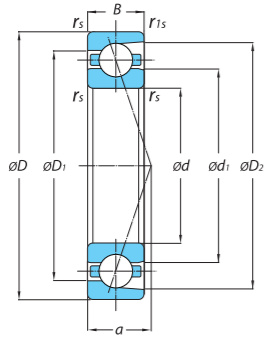
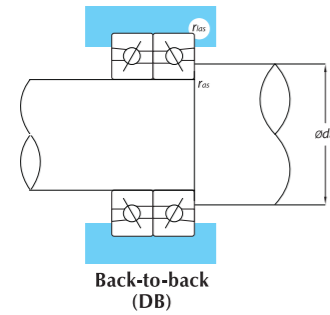

Table 1.1 Value of Factors X and Y

Normal Contact Angle	if ₀ F _a * / C _{or}	e	Single, DT				DB or DF			
			F _a /F _r ≤ e		F _a /F _r > e		F _a /F _r ≤ e		F _a /F _r > e	
			X	Y	X	Y	X	Y	X	Y
15	0.178	0.38			1.47	1.65			2.39	
	0.357	0.4			1.4	1.57			2.28	
	0.714	0.43			1.3	1.46			2.11	
	1.07	0.46	1	0	0.14	1.23	1	0.72	2	
	1.43	0.47			1.19	1.34			1.93	
	2.14	0.5			1.12	1.26			1.82	
	3.57	0.55			1.02	1.14			1.66	
	5.35	0.56			1	1.12			1.63	
	18	0.57	1	0	0.43	1	1.09	0.7	1.63	
	25	0.68	1	0	0.41	0.87	1	0.92	1.67	
30	0.8	1	0	0.39	0.76	1	0.78	1.63		
40	1.14	1	0	0.35	0.57	1	0.55	0.93		
50	1.49			0.73	1	1.37	0.57	0.73		
55	1.79			0.81	1	1.6	0.56	0.81		
60	2.17			0.92	1	1.9	0.55	0.92		

For i, use 2 for DB, DF and 1 for DT



Back-to-back (DB)

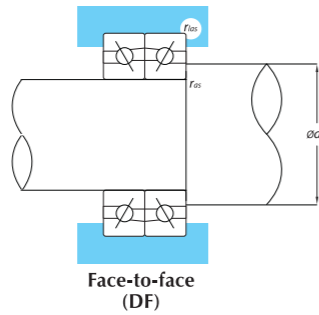

Face-to-face (DF)

Table 2.1 Static Equivalent Load Po=X₀F_r+Y₀F_a

Contact Angle	Single, DT		DB or DF	
	X ₀	Y ₀	X ₀	Y ₀
15	0.5	0.46	1	0.92
18	0.5	0.42	1	0.84
25	0.5	0.38	1	0.76
30	0.5	0.33	1	0.66
40	0.5	0.26	1	0.52

Boundary Dimensions (mm)					Basic Load Ratings				Bearing Numbers Type	Load Center (mm) a	Limiting Speeds n _l (min ⁻¹)	
d	D	B	r _{s min}	r _{1s min}	Dynamic C _r		Static C _{or}				Grease	Oil
10	26	8	0.3	0.15	5.00	510	2.33	238	7000A	9.2	46600	60300
12	28	8	0.3	0.15	5.05	515	2.46	251	7001A	10	41900	54200
15	32	9	0.3	0.15	5.75	590	3.10	320	7002A	11.5	35700	46100
17	35	10	0.3	0.15	6.05	620	3.50	360	7003A	16	32300	41800
20	42	12	0.6	0.3	10.3	1050	6.05	620	7004A	14.9	27000	35000
25	47	12	0.6	0.3	10.7	1100	6.15	630	7005A	16.4	23300	30200
30	55	13	1.0	0.6	13.9	1420	9.40	960	7006A	18.8	19800	25500
35	62	14	1.0	0.6	17.4	1780	12.5	1280	7007A	21.0	17400	22400
40	68	15	1.0	0.6	18.1	1850	14.2	1450	7008A	23.1	15500	20100
45	75	16	1.0	0.6	22.4	2290	18.6	1900	7009A	25.8	14000	18100
50	80	16	1.0	0.6	23.6	2410	20.0	2040	7010A	28.2	12900	16700

Angular Contact Ball Bearings 72C Series | d 10~100mm

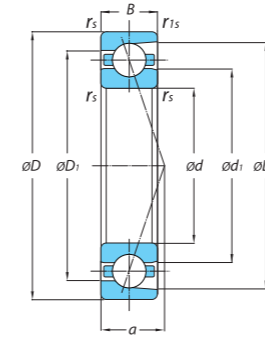
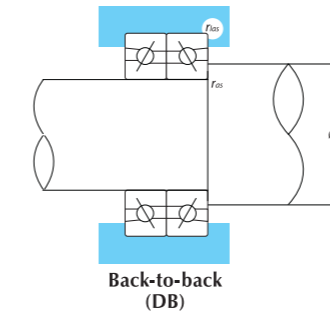

Table 1.1 Value of Factors X and Y

Normal Contact Angle	if ₀ F _a * / C _{or}	e	Single, DT				DB or DF			
			F _a /F _r ≤ e		F _a /F _r > e		F _a /F _r ≤ e		F _a /F _r > e	
			X	Y	X	Y	X	Y	X	Y
15	0.178	0.38			1.47	1.65			2.39	
	0.357	0.4			1.4	1.57			2.28	
	0.714	0.43			1.3	1.46			2.11	
	1.07	0.46	1	0	0.14	1.23	1	0.72	2	
	1.43	0.47			1.19	1.34			1.93	
	2.14	0.5			1.12	1.26			1.82	
	3.57	0.55			1.02	1.14			1.66	
	5.35	0.56			1	1.12			1.63	
	18	0.57	1	0	0.43	1	1.09	0.7	1.63	
	25	0.68	1	0	0.41	0.87	1	0.92	1.67	
30	0.8	1	0	0.39	0.76	1	0.78	1.63		
40	1.14	1	0	0.35	0.57	1	0.55	0.93		
50	1.49			0.73	1	1.37	0.57	0.73		
55	1.79			0.81	1	1.6	0.56	0.81		
60	2.17			0.92	1	1.9	0.55	0.92		

For i, use 2 for DB, DF and 1 for DT



Back-to-back (DB)

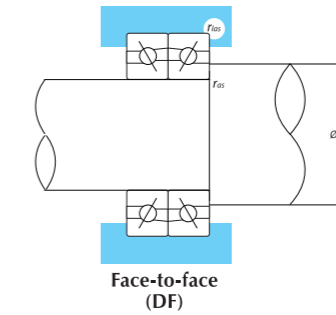

Face-to-face (DF)

Table 2.1 Static Equivalent Load Po=X₀F_r+Y₀F_a

Contact Angle	Single, DT		DB or DF	
	X ₀	Y ₀	X ₀	Y ₀
15	0.5	0.46	1	0.92
18	0.5	0.42	1	0.84
25	0.5	0.38	1	0.76
30	0.5	0.33	1	0.66
40	0.5	0.26	1	0.52

Boundary Dimensions (mm)					Basic Load Ratings				Bearing Numbers Type	Load Center (mm) a	Limiting Speeds n _l (min ⁻¹)	
d	D	B	r _{s min}	r _{1s min}	Dynamic C _r		Static C _{or}				Grease	Oil
10	30	9	0.6	0.3	5.40	555	2.63	269	7200C	7.0	42900	55600
12	32	10	0.6	0.3	7.05	720	3.45	355	7201C	8.0	40000	51800
15	35	11	0.6	0.3	8.95	915	4.50	460	7202C	9.0	35200	45600
17	40	12	0.6	0.3	11.1	1140	5.75	590	7203C	10.0	30500	39600
20	47	14	1.0	0.6	14.6	1490	8.15	835	7204C	11.5	25500	33000
25	52	15	1.0	0.6	16.5	1690	10.3	1050	7205C	13.0	22600	29200
30	62	16	1.0	0.6	23.0	2350	14.7	1500	7206C	14.0	18900	24500
35	72	17	1.1	0.6	30.0	3100	19.9	2030	7207C	16.0	16400	21300
40	80	18	1.1	0.6	36.0	3700	25.2	2570	7208C	17.0	14700	19000
45	85	19	1.1	0.6	40.5	4150	28.8	2940	7209C	18.0	13500	17500
50	90	20	1.1	0.6	42.5	4350	31.5	3250	7210C	19.0	12600	16300
55	100	21	1.5	1.0	52.5	5400	40.0	4100	7211C	21.0	11400	14700
60	110	22	1.5	1.0	64.0	6550	49.5	5050	7212C	22.0	10200	13200
65	120	23	1.5	1.0	69.5	7100	54.5	5600	7213C	24.0	9500	12300
70	125	24	1.5	1.0	76.0	7750	60.0	6150	7214C	25.0	9000	11700
75	130	25	1.5	1.0	79.0	8100	65.5	6700	7215C	26.0	8500	11000
80	140	26	2.0	1.0	92.5	9450	77.0	7900	7216C	28.0	8000	10400
85	150	28	2.0	1.0	103	10600	90.0	9200	7217C	30.0	7500	9700
90	160	30	2.0	1.0	122	12500	104	10700	7218C	32.0	7000	9100
95	170	32	2.1	1.1	139	14200	119	12200	7219C	34.0	6600	8600
100	180	34	2.1	1.1	149	15200	126	12900	7220C	36.0	6300	8100

Angular Contact Ball Bearings 72A Series | d 10~50mm

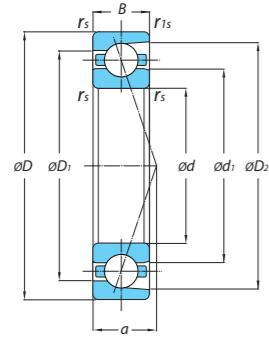
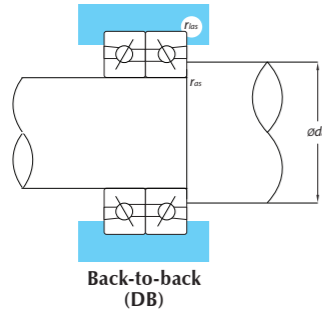

Table 1.1 Value of Factors X and Y

Normal Contact Angle	if ₀ F _a * / C _{or}	e	Single, DT				DB or DF			
			F _a /F _r ≤ c		F _a /F _r > c		F _a /F _r ≤ c		F _a /F _r > c	
			X	Y	X	Y	X	Y	X	Y
15	0.178	0.38			1.47			1.65	2.39	
	0.357	0.4			1.4			1.57	2.28	
	0.714	0.43			1.3			1.46	2.11	
	1.07	0.46			1.23			1.38	2	
	1.43	0.47	1	0	1.19	1	0.72	0.34	1.93	
	2.14	0.5			1.12			0.26	1.82	
	3.57	0.55			1.02			1.14	1.66	
5.35	0.56			1			1.12	1.63		
18	0.57	1	0	0.43	1	1	1.09	0.7	1.63	
25	0.68	1	0	0.41	0.87	1	0.92	1.67	1.41	
30	0.8	1	0	0.39	0.76	1	0.78	1.63	1.24	
40	1.14	1	0	0.35	0.57	1	0.55	0.57	0.93	
50	1.49			0.73	1	1.37	0.57	0.73		
55	1.79			0.81	1	1.6	0.56	0.81		
60	2.17			0.92	1	1.9	0.55	0.92		

For i, use 2 for DB, DF and 1 for DT



Back-to-back (DB)

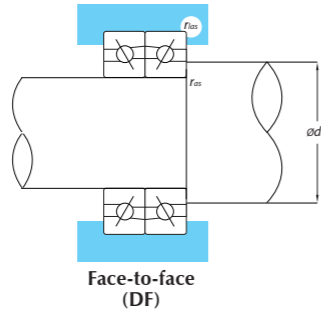

Face-to-face (DF)

Table 2.1 Static Equivalent Load Po=XoFr+YoFa

Contact Angle	Single, DT		DB or DF	
	Xo	Yo	Xo	Yo
15	0.5	0.46	1	0.92
18	0.5	0.42	1	0.84
25	0.5	0.38	1	0.76
30	0.5	0.33	1	0.66
40	0.5	0.26	1	0.52

Boundary Dimensions (mm)					Basic Load Ratings				Bearing Numbers Type	Load Center (mm)	Limiting Speeds n _l (min ⁻¹)	
d	D	B	r _{s min}	r _{1s min}	Dynamic C _r		Static C _{or}				a	Grease
10	30	9	0.6	0.3	5.05	515	2.45	250	7200A	10.3	27700	36000
12	32	10	0.6	0.3	6.67	680	3.24	330	7201A	11.4	25800	33500
15	35	11	0.6	0.3	8.44	860	4.27	432	7202A	12.7	22700	29400
17	40	12	0.6	0.3	10.5	1070	5.40	550	7203A	14.2	19700	25500
20	47	14	1.0	0.6	13.6	1390	7.55	770	7204A	16.7	16400	21300
25	52	15	1.0	0.6	15.4	1570	9.47	965	7205A	18.6	14600	18800
30	62	16	1.0	0.6	21.3	2170	13.6	1390	7206A	21.3	12200	15800
35	72	17	1.1	0.6	28.2	2870	18.5	1890	7207A	23.9	10600	13700
40	80	18	1.1	0.6	33.8	3450	20.7	2110	7208A	26.3	9480	12300
45	85	19	1.1	0.6	37.8	3850	26.8	2730	7209A	28.4	8700	11300
50	90	20	1.1	0.6	39.7	4050	29.3	2990	7210A	30.2	8120	10500

Angular Contact Ball Bearings 79C Series | d 12~100mm

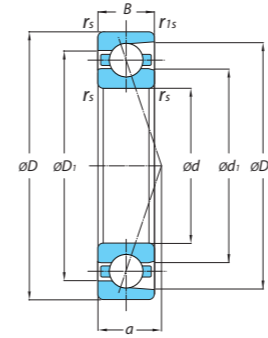
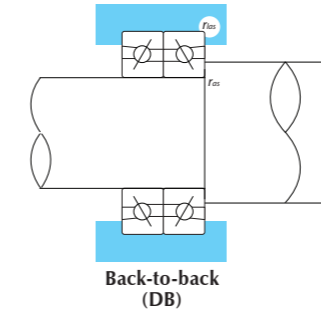

Table 1.1 Value of Factors X and Y

Normal Contact Angle	if ₀ F _a * / C _{or}	e	Single, DT				DB or DF			
			F _a /F _r ≤ c		F _a /F _r > c		F _a /F _r ≤ c		F _a /F _r > c	
			X	Y	X	Y	X	Y	X	Y
15	0.178	0.38			1.47			1.65	2.39	
	0.357	0.4			1.4			1.57	2.28	
	0.714	0.43			1.3			1.46	2.11	
	1.07	0.46			1.23			1.38	2	
	1.43	0.47	1	0	1.19	1	0.72	0.34	1.93	
	2.14	0.5			1.12			0.26	1.82	
	3.57	0.55			1.02			1.14	1.66	
5.35	0.56			1			1.12	1.63		
18	0.57	1	0	0.43	1	1	1.09	0.7	1.63	
25	0.68	1	0	0.41	0.87	1	0.92	1.67	1.41	
30	0.8	1	0	0.39	0.76	1	0.78	1.63	1.24	
40	1.14	1	0	0.35	0.57	1	0.55	0.57	0.93	
50	1.49			0.73	1	1.37	0.57	0.73		
55	1.79			0.81	1	1.6	0.56	0.81		
60	2.17			0.92	1	1.9	0.55	0.92		

For i, use 2 for DB, DF and 1 for DT



Back-to-back (DB)

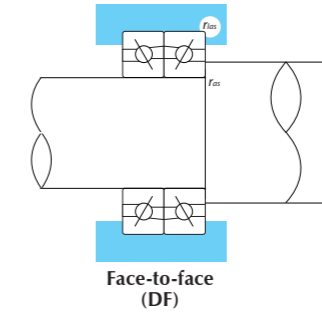

Face-to-face (DF)

Table 2.1 Static Equivalent Load Po=XoFr+YoFa

Contact Angle	Single, DT		DB or DF	
	Xo	Yo	Xo	Yo
15	0.5	0.46	1	0.92
18	0.5	0.42	1	0.84
25	0.5	0.38	1	0.76
30	0.5	0.33	1	0.66
40	0.5	0.26	1	0.52

Boundary Dimensions (mm)					Basic Load Ratings				Bearing Numbers Type	Limiting Speeds n _l (min ⁻¹)	
d	D	B	r _{s min}	r _{1s min}	Dynamic C _r		Static C _{or}			a	Grease
12	24	6	0.3	0.15	3.36	343	1.86	190	7901C	60000	93000
15	28	7	0.3	0.15	4.76	486	2.64	269	7902C	51000	78000
17	30	7	0.3	0.15	5.00	511	2.93	299	7903C	46000	71000
20	37	9	0.3	0.15	6.95	709	4.24	432	7904C	38000	59000
25	42	9	0.3	0.15	7.84	800	5.42	553	7905C	33000	50000
30	47	9	0.3	0.15	8.31	848	6.28	640	7906C	29000	44000
35	55	10	0.6	0.3	10.96	1119	8.54	872	7907C	24000	37000
40	62	12	0.6	0.3	13.97	1425	11.14	1137	7908C	21000	33000
45	68	12	0.6	0.3	14.70	1500	12.58	1283	7909C	20000	30000
50	72	12	0.6	0.3	14.95	1526	13.40	1367	7910C	18000	27000
55	80	13	1	0.6	18.54	1892	16.91	1725	7911C	16000	25000
60	85	13	1	0.6	19.41	1981	18.65	1903	7912C*	15000	23000
65	90	13	1	0.6	19.69	2009	19.50	1990	7913C*	14000	22000
70	100	16	1	0.6	23.88	2437	24.10	2459	7914C	13000	20000
75	105	16	1	0.6	29.35	2995	30.31	3092	7915C*	12000	19000
80	110	16	1	0.6	34.57	3527	36.00	3673	7916C*	12000	18000
85	120	18	1.1	0.6	41.02	4185	43.93	4483	7917C*	10000	16000
90	125	18	1.1	0.6	40.61	4144	44.05	4495	7918C*	10000	16000
95	130	18	1.1	0.6	41.24	4208	45.74	4668	7919C*	10000	15000
100	140	20	1.1	0.6	51.54	5259	56.28	5743	7920C*	9000	14000

Angular Contact Ball Bearings 79AD Series | d 12~100mm

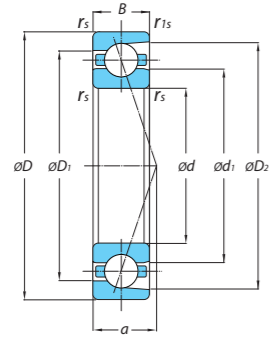
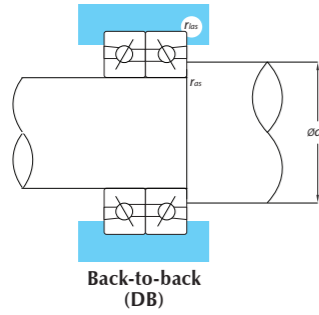

Table 1.1 Value of Factors X and Y

Normal Contact Angle	if ₀ F _a * / C _{or}	e	Single, DT				DB or DF			
			F _a /F _r ≤ c		F _a /F _r > c		F _a /F _r ≤ c		F _a /F _r > c	
			X	Y	X	Y	X	Y	X	Y
15	0.178	0.38				1.47			1.65	2.39
	0.357	0.4				1.4			1.57	2.28
	0.714	0.43				1.3			1.46	2.11
	1.07	0.46				1.23			1.38	2
	1.43	0.47	1	0	0.14	1.19	1	0.72	1.34	1.93
	2.14	0.5				1.12			1.26	1.82
	3.57	0.55				1.02			1.14	1.66
	5.35	0.56				1			1.12	1.63
18	0.57	0.57	1	0	0.43	1	1	1.09	0.7	1.63
25	0.68	1	0	0.41	0.87	1	0.92	1.67	1.41	1.24
30	0.8	1	0	0.39	0.76	1	0.78	1.63	1.24	0.93
40	1.14	1	0	0.35	0.57	1	0.55	0.57	0.93	
50	1.49	1				1.37	0.57	0.73		
55	1.79	1				0.81	1	1.6	0.56	0.81
60	2.17	1				0.92	1	1.9	0.55	0.92

For i, use 2 for DB, DF and 1 for DT



Back-to-back (DB)

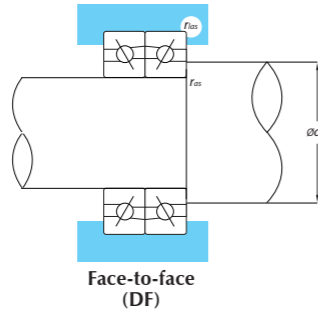

Face-to-face (DF)

Table 2.1 Static Equivalent Load P₀=X₀F_r+Y₀F_a

Contact Angle	Single, DT		DB or DF	
	X ₀	Y ₀	X ₀	Y ₀
15	0.5	0.46	1	0.92
18	0.5	0.42	1	0.84
25	0.5	0.38	1	0.76
30	0.5	0.33	1	0.66
40	0.5	0.26	1	0.52

Boundary Dimensions (mm)					Basic Load Ratings				Bearing Numbers Type	Limiting Speeds n _L (min ⁻¹)	
d	D	B	r _{s min}	r _{1s min}	Dynamic C _r		Static C _{or}			Grease	Oil
12	24	6	0.3	0.15	3.20	326	1.77	181	7901AD*	52000	80000
15	28	7	0.3	0.15	4.54	464	2.53	258	7902AD	44000	67000
17	30	7	0.3	0.15	4.76	486	2.80	286	7903AD	40000	61000
20	37	9	0.3	0.15	6.61	675	4.05	413	7904AD	33000	51000
25	42	9	0.3	0.15	7.44	759	5.14	525	7905AD*	28000	43000
30	47	9	0.3	0.15	7.86	802	5.94	606	7906AD*	24000	37000
35	55	10	0.6	0.3	10.37	1058	8.09	825	7907AD*	21000	32000
40	62	12	0.6	0.3	13.20	1347	10.55	1077	7908AD*	18000	28000
45	68	12	0.6	0.3	13.88	1416	11.95	1219	7909AD*	16000	25000
50	72	12	0.6	0.3	14.11	1440	12.63	1289	7910AD*	16000	24000
55	80	13	1	0.6	17.50	1786	15.97	1630	7911AD*	14000	21000
60	85	13	1	0.6	18.32	1869	17.54	1790	7912AD*	13000	20000
65	90	13	1	0.6	18.55	1892	18.17	1854	7913AD*	12000	19000
70	100	16	1	0.6	22.49	2295	22.47	2293	7914AD*	11000	17000
75	105	16	1	0.6	27.68	2825	28.43	2901	7915AD*	10000	16000
80	110	16	1	0.6	32.63	3329	33.90	3459	7916AD*	10000	15000
85	120	18	1.1	0.6	38.72	3951	41.37	4221	7917AD*	9000	14000
90	125	18	1.1	0.6	38.29	3907	41.25	4209	7918AD*	8000	13000
95	130	18	1.1	0.6	38.84	3964	42.64	4351	7919AD*	8000	13000
100	140	20	1.1	0.6	48.65	4964	52.99	5407	7920AD*	8000	12000

Angular Contact Ball Bearings BT Series | d 90~130mm

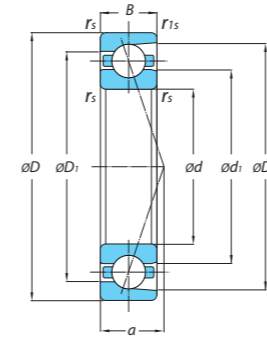
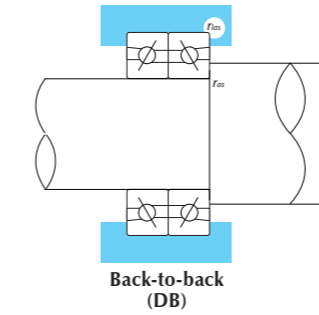

Table 1.1 Value of Factors X and Y

Normal Contact Angle	if ₀ F _a * / C _{or}	e	Single, DT				DB or DF			
			F _a /F _r ≤ c		F _a /F _r > c		F _a /F _r ≤ c		F _a /F _r > c	
			X	Y	X	Y	X	Y	X	Y
15	0.178	0.38				1.47			1.65	2.39
	0.357	0.4				1.4			1.57	2.28
	0.714	0.43				1.3			1.46	2.11
	1.07	0.46				1.23			1.38	2
	1.43	0.47	1	0	0.14	1.23	1	0.72	1.38	1.93
	2.14	0.5				1.19			1.34	1.82
	3.57	0.55				1.12			1.26	1.66
	5.35	0.56				1.02			1.14	1.63
18	0.57	0.57	1	0	0.43	1	1	1.09	0.7	1.63
25	0.68	1	0	0.41	0.87	1	0.92	1.67	1.41	1.24
30	0.8	1	0	0.39	0.76	1	0.78	1.63	1.24	0.93
40	1.14	1	0	0.35	0.57	1	0.55	0.57	0.93	
50	1.49	1				1.37	0.57	0.73		
55	1.79	1				0.81	1	1.6	0.56	0.81
60	2.17	1				0.92	1	1.9	0.55	0.92

For i, use 2 for DB, DF and 1 for DT



Back-to-back (DB)

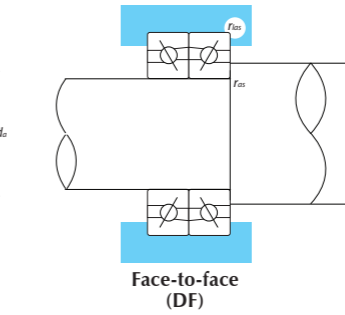

Face-to-face (DF)

Table 2.1 Static Equivalent Load P₀=X₀F_r+Y₀F_a

Contact Angle	Single, DT		DB or DF	
	X ₀	Y ₀	X ₀	Y ₀
15	0.5	0.46	1	0.92
18	0.5	0.42	1	0.84
25	0.5	0.38	1	0.76
30	0.5	0.33	1	0.66
40	0.5	0.26	1	0.52

Boundary Dimensions (mm)					Basic Load Ratings				Bearing Numbers Type	Load Center (mm)	Limiting Speeds n _L (min ⁻¹)	
d	D	B	r _{s min}	r _{1s min}	Dynamic C _r		Static C _{or}				a	Grease
100	150	45	1.5	1	41	4180	39	3980	BT020A	47.3	5300	6600
120	180	27	2	1	41.5	4230	43	4390	BT024A	56.8	4400	5500
90	140	22.5	1.5	1	28.9	2950	27.4	2800	BT018B	59.5	5000	6200
100	150	45	1.5	1	36.5	3720	35	3570	BT020B	63.7	4600	5700
110	170	27	2	1	36.5	3720	36	3670	BT022B	72.2	4100	5100
130	200	31.5	2	1	47	4800	47	4800	BT026B	85.0	3400	4300

Angular Contact Ball Bearings

Bearing Designations High Speed Series

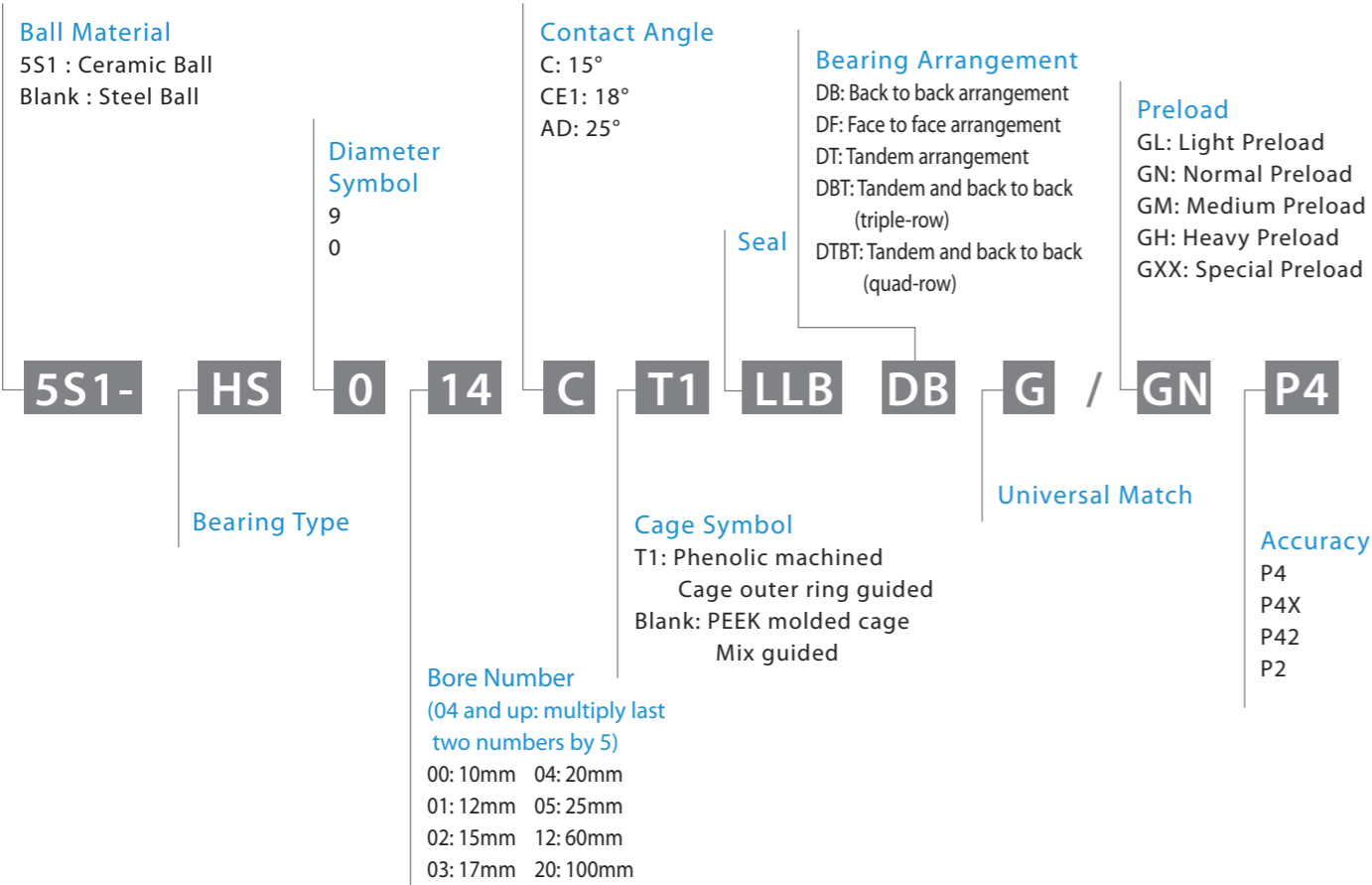
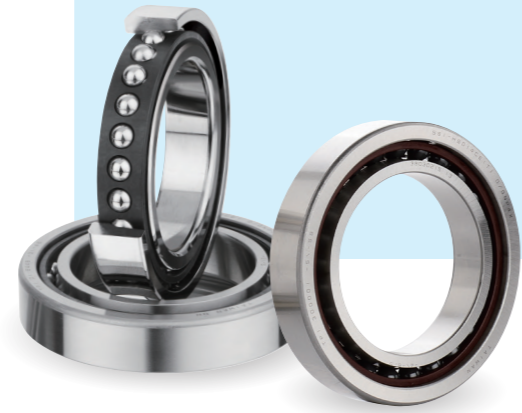

Interchange

Description	Interchange						
	TPI	NSK	SKF	FAG	NTN	KOYO	GMN
Part No.	HS9XX	XXBNR19	719XXCE	HS719XX	HSB9XX	HAR9XX	SM619XX
	HS0XX	XXBNR10	70XXCE	HS70XX	HSB0XX	HAR0XX	SM60XX
Series	High Speed						
Ceramic Ball	5S1	SN24	HC	HC	5S	3NC	HY
Contact Angle	15°	C	C	CD	C	C	C
	18°	CE1	BNR	—	—	—	18°
	25°	AD	A5, BER	ACD	E	AD	—
Cage	Phenolic Machined Cage Outer ring guided	T1	TR	—	T	T1	FT
	PEEK Molded Cage Mix guided	Blank	TYN	TN, TN9	—	T2	FG
Seal	LLB	V1V	S	2RSD	LLB	—	2RZ (KH)
Arrangement	DB	DB	DB	DB	DB	DB	DB
	DF	DF	DF	DF	DF	DF	DF
	DT	DT	DT	DT	DT	DT	DT
	DBT	DBD	TBT	—	DBT	DBD	TBT
	DFT	DFD	TFT	—	DFT	DFD	TFT
	DTBT	DBB	QBC	—	DTBT	DBB	QBC
Single Universal Match	G	SU	G	U	G	G	U
Duplex Universal Match	D2G	DU	DG	DU	GD2	—	—
Preload	Light Preload	GL	EL	A	—	GL	—
	Normal Preload	GN	L	B	L	GN	L
	Medium Preload	GM	M	C	M	GM	M
	Heavy Preload	GH	H	—	H	—	H
Precision Grade	JIS 4 / ABEC 7	P4	P4	P4	—	P4	P4
	JIS 4 Special Tolerance	P4X ¹⁾	P4Y	—	P4S	—	K5
	JIS 4 Special Tolerance	P42 ²⁾	P3	P4A	—	P42	—
	JIS 2 / ABEC 9	P2	P2	PA9A	—	P2	P2

1) P4X: Special bore and outer diameter. Others are JIS 4.

2) P42: JIS 4 dimensional tolerances and JIS 2 running accuracy.

This interchange table is designed to assist in identifying equivalent models for TPI's products.

However, as other manufacturers may frequently update their bearing designations, we assume no liability for any inaccuracies in the information provided in this table.

Applications

Machine tool spindles

Features

1. Well-developed HS series to meet wide range of demands from customers.
2. P4 grade precision and universal match design for all series to meet all kinds of bearing arrangement requests.
3. Optimizing inner design of the bearings, lower the temperature rises and increase the limiting speed.

Precision Ball Screw Support Bearings

Bearing Designations

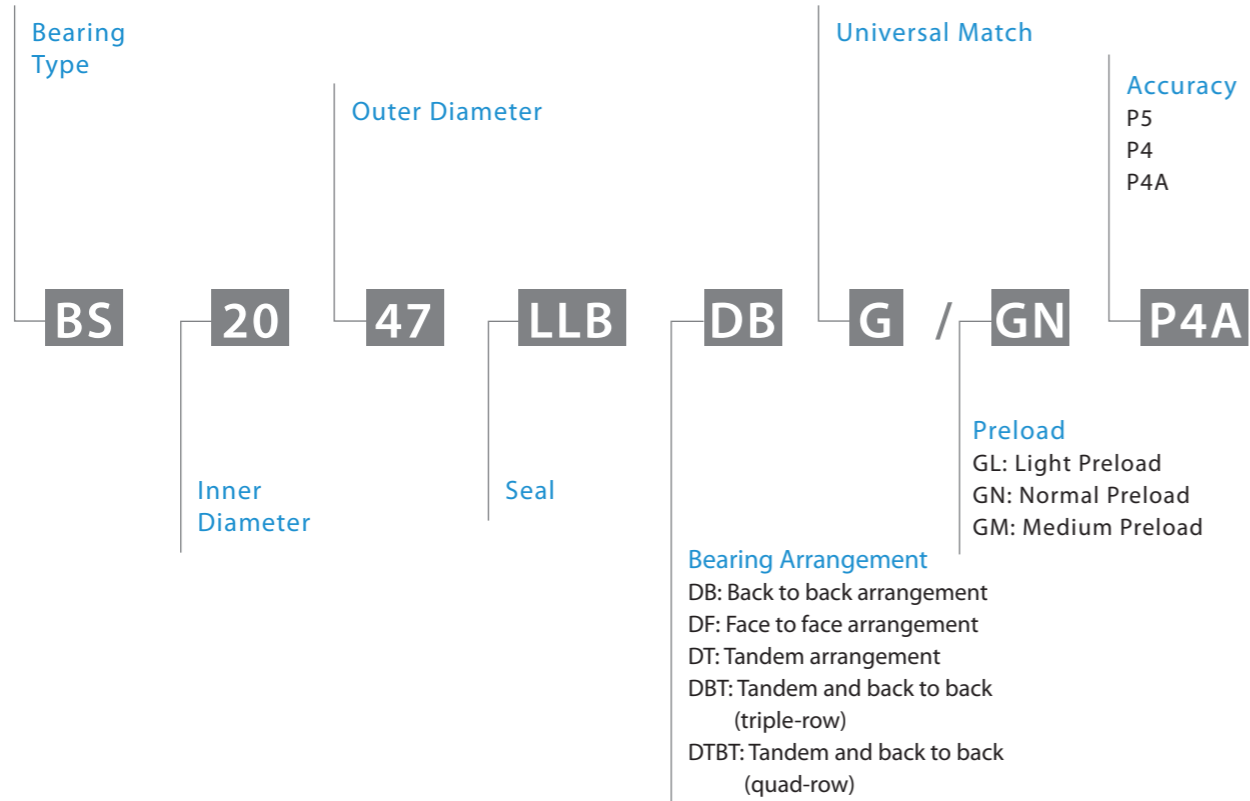

Interchange

Description	Interchange						
	TPI	NSK	SKF	FAG	NTN	KOYO	NACHI
Part No.	BS3062	30TAC62	BSD3062	BSB3062	BST30X62	SAC3062	30TAB06
Internal Design Code	—	C	C	—	—	B	—
Seals	Non-Contact Seals	LLB	V1V	2RZ	2Z	—	2NKE
	Contact Seals	LLE	DDG	2RS	2RS	LXL	—
Arrangement		DB	DB	DB	—	DB	DB
		DF	DF	DF	—	DF	DF
		DT	DT	DT	D	DT	DT
		DBT	DBD	TBT	T	DBT	DBD
Single Universal Match	G	SU	G	SU	G	G	U
Duplex Universal Match	D2G	DU	DG	—	GD2	—	DU
Preload	Normal Preload	GN	H	A	Blank	-1B	Blank
	JIS 5 / ABEC 5	P5	—	—	—	P5	5Z
	JIS 4 / ABEC 7	P4	PN7C	Blank	Blank	P4	4Z
Special Tolerance	P4A ¹⁾	—	—	—	UP	—	—

1) P4A: Special bore and outer diameter. Others are JIS 4.

This interchange table is designed to assist in identifying equivalent models for TPI's products. However, as other manufacturers may frequently update their bearing designations, we assume no liability for any inaccuracies in the information provided in this table.

Applications

Ball screw support

Features

1. With unique heat treatment process, the wear resistance of the bearings has been significantly enhanced.
2. High precision P4 & P4A grade with universal match.
3. Provide light contact seal against contamination with excellent low torque and longer bearing life.

Double-Row Cylindrical Roller Bearings

Bearing Designations

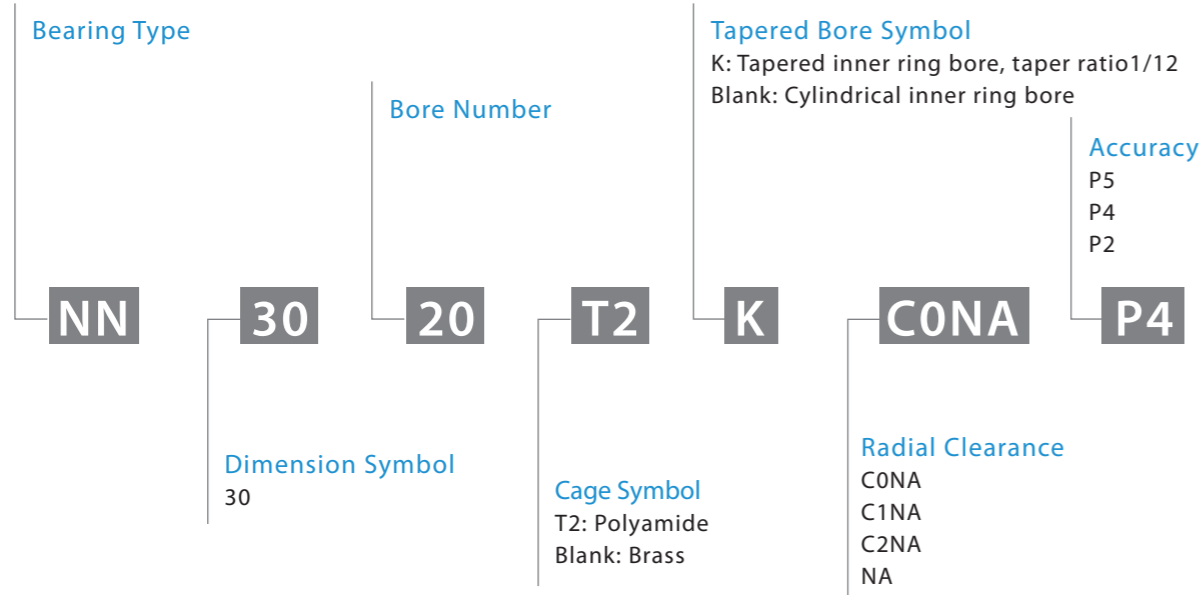
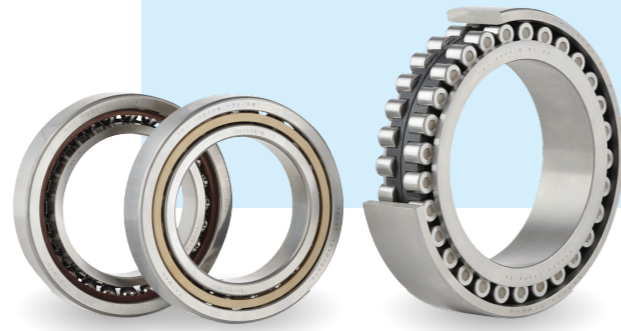

Double-Row Cylindrical Roller Bearings | d 30~130mm

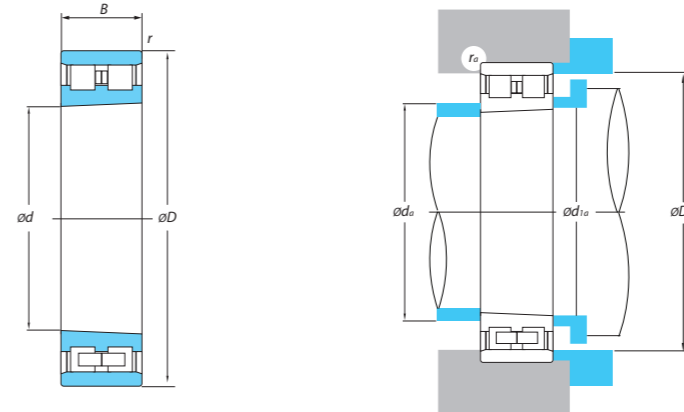

Boundary Dimensions (mm)				Basic Load Ratings				Circumscribed Circle Diameter of Roller (mm)	Bearing Numbers Type	Limiting Speeds n_l (min ⁻¹)	
d	D	B	r	Dynamic C_r		Static C_{or}				Grease	Oil
30	55	19	1.0	31.0	3150	37.0	3800	48.5	NN3006K	16300	19800
80	125	34	1.1	118	12000	182	18600	113	NN3016K	6800	8300
90	140	37	1.5	146	14900	232	23600	127	NN3018K	6000	7300
100	150	37	1.5	156	15900	261	26600	137	NN3020K	5600	6700
110	170	45	2	234	23900	382	38900	155	NN3022K	5000	6000
120	180	46	2	238	24300	400	40800	165	NN3024K	4600	5600
130	200	52	2	291	29700	486	49500	182	NN3026K	4200	5100

Appendix I Required Information for Deep Groove Ball Bearings Selection

Installation location		
Competitors bearing		
Max load		Radial load: _____ kgf Axial load: _____ kgf Rotation speed: _____ RPM Operation temp.: _____ °C Max. rotation speed: _____ RPM
Impact load		<input type="checkbox"/> Yes <input type="checkbox"/> No <input type="checkbox"/> Heavy <input type="checkbox"/> Medium <input type="checkbox"/> Light
Lubrication		<input type="checkbox"/> Oil _____ <input type="checkbox"/> Oil bath <input type="checkbox"/> Spray <input type="checkbox"/> Others _____ <input type="checkbox"/> Grease _____ <input type="checkbox"/> Pre-fill <input type="checkbox"/> Refill : <input type="checkbox"/> Necessary <input type="checkbox"/> No refill
Life require		<input type="checkbox"/> General <input type="checkbox"/> Others _____
Noise require		<input type="checkbox"/> General <input type="checkbox"/> Extreme
Fit	Shaft	<input type="checkbox"/> Steel <input type="checkbox"/> Solid <input type="checkbox"/> Grind <input type="checkbox"/> Hollow <input type="checkbox"/> Turning Shaft diameter: ϕ _____ \pm _____ μ m Shaft shoulder: ϕ _____
	Housing	<input type="checkbox"/> Steel <input type="checkbox"/> Aluminum <input type="checkbox"/> Grind <input type="checkbox"/> Other _____ <input type="checkbox"/> Turning Housing diameter: ϕ _____ \pm _____ μ m Housing shoulder: ϕ _____
Bearing assembling way		<input type="checkbox"/> Vertical <input type="checkbox"/> Horizontal <input type="checkbox"/> Shaft first <input type="checkbox"/> Housing first <input type="checkbox"/> Punch <input type="checkbox"/> Press <input type="checkbox"/> Air pressure <input type="checkbox"/> Hydraulic <input type="checkbox"/> Other _____ Fixture <input type="checkbox"/> Yes <input type="checkbox"/> No
Assembling environment		<input type="checkbox"/> Clean <input type="checkbox"/> Normal <input type="checkbox"/> Mess
Assembling ability		<input type="checkbox"/> Weak <input type="checkbox"/> Good <input type="checkbox"/> Excellent
Operation environment		<input type="checkbox"/> General <input type="checkbox"/> Low temp. <input type="checkbox"/> High temp. <input type="checkbox"/> High humidity <input type="checkbox"/> Heavy dusty <input type="checkbox"/> Corrosive fluids
Test conditions		<input type="checkbox"/> Continuous operation <input type="checkbox"/> Loading: Radial, Fr: _____ kgf Axial, Fa: _____ kgf <input type="checkbox"/> Temp.: _____ °C <input type="checkbox"/> Time: _____ Hrs <input type="checkbox"/> Judgment standard: <input type="checkbox"/> Cycle operation <input type="checkbox"/> Loading: Radial, Fr: _____ kgf Axial, Fa: _____ kgf <input type="checkbox"/> Temp.: _____ °C <input type="checkbox"/> Time: _____ Hrs <input type="checkbox"/> Judgment standard:

Appendix II Required Information for Spindle Bearings Selection

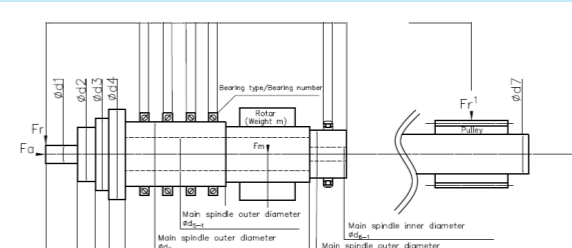
(1) Machine type	<input type="checkbox"/> NC lathe <input type="checkbox"/> Machine center <input type="checkbox"/> Grinding machine <input type="checkbox"/> Others _____
(2) Main spindle orientation	<input type="checkbox"/> Vertical <input type="checkbox"/> Horizontal <input type="checkbox"/> Variable-direction <input type="checkbox"/> Inclined <input type="checkbox"/> Others _____
(3) Diameter of main spindle	<input type="checkbox"/> #30 <input type="checkbox"/> #40 <input type="checkbox"/> #50 <input type="checkbox"/> Others _____
(4) Shape and mounting-related dimension of main spindle	
(5) Intended bearing type, dimension and preload method	Front: <input type="checkbox"/> Cylindrical roller type <input type="checkbox"/> Angular contact type [<input type="checkbox"/> sealing] Rear: <input type="checkbox"/> Cylindrical roller type <input type="checkbox"/> Angular contact type [<input type="checkbox"/> sealing] Preloading system: <input type="checkbox"/> Fixed-position <input type="checkbox"/> Fixed-pressure
(6) Slide system free side	<input type="checkbox"/> Cylindrical roller bearing <input type="checkbox"/> Ball bushing (availability of cooling)
(7) Lubrication method	<input type="checkbox"/> Grease <input type="checkbox"/> Air-oil <input type="checkbox"/> Oil mist
(8) Drive system	<input type="checkbox"/> Built-in motor <input type="checkbox"/> Belt drive <input type="checkbox"/> Coupling
(9) Presence/absence of jacket cooling arrangement on bearings area	<input type="checkbox"/> Yes <input type="checkbox"/> No
(10) Load conditions (machining conditions)	Max. speed: _____ Min-1 Radial load Fr: _____ N Axial load Fa: _____ N Moment: _____ N-mm Tightening force: _____ N
(11) Shaft and housing	Shaft material: _____ Shaft tolerance: _____ mm Housing material: _____ Housing tolerance: _____ mm Housing outer diameter: _____ mm Hollow shaft bore diameter: _____ mm Fits on shaft : _____ mm Fits on housing : _____ mm Spacer length: _____ mm Ambient temperature: _____ °C
(12) Requirement value	Rigidity: _____ N/um Preload: _____ N Life: _____ hours
(13) Specific request	

Appendix III Dimensional Tolerance for Housing Shaft and Bore

Dimensional tolerance for shaft | Unit: μm

Diameter division d(mm)		f5		f6		g5		g6		h4		h5		h6	
over	incl.	low	high	low	high	low	high	low	high	low	high	low	high	low	high
3	6	-10	-15	-10	-18	-4	-9	-4	-12	0	-4	0	-5	0	-8
6	10	-13	-19	-13	-22	-5	-11	-5	-14	0	-4	0	-6	0	-9
10	18	-16	-24	-16	-27	-6	-14	-6	-17	0	-5	0	-8	0	-11
18	30	-20	-29	-20	-33	-7	-16	-7	-20	0	-6	0	-9	0	-13
30	40	-25	-36	-25	-41	-9	-20	-9	-25	0	-7	0	-11	0	-16
40	50	-30	-43	-30	-49	-10	-23	-10	-29	0	-8	0	-13	0	-19

d(mm)		h7		h8		js4		j5		js5		j6		js6	
over	incl.	low	high	low	high	low	high	low	high	low	high	low	high	low	high
3	6	0	-12	0	-18	+2	-2	+3	-2	+2.5	-2.5	+6	-2	+4	-4
6	10	0	-15	0	-22	+2	-2	+4	-2	+3	-3	+7	-2	+4.5	-4.5
10	18	0	-18	0	-27	+2.5	-2.5	+5	-3	+4	-4	+8	-3	+5.5	-5.5
18	30	0	-21	0	-33	+3	-3	+5	-4	+4.5	-4.5	+9	-4	+6.5	-6.5
30	40	0	-25	0	-39	+3.5	-3.5	+6	-5	+5.5	-5.5	+11	-5	+8	-8
40	50	0	-30	0	-46	+4	-4	+6	-7	+6.5	-6.5	+12	-7	+9.5	-9.5

d(mm)		j7		k4		k5		k6		m5		m6		n5	
over	incl.	low	high	low	high	low	high	low	high	low	high	low	high	low	high
3	6	+8	-4	+5	+1	+6	+1	+9	+1	+9	+4	+12	+4	+13	+8
6	10	+10	-5	+5	+1	+7	+1	+10	+1	+12	+6	+15	+6	+16	+10
10	18	+12	-6	+6	+1	+9	+1	+12	+1	+15	+7	+18	+7	+20	+12
18	30	+13	-8	+8	+2	+11	+2	+15	+2	+17	+8	+21	+8	+24	+15
30	40	+15	-10	+9	+2	+13	+2	+18	+2	+20	+9	+25	+9	+28	+17
40	50	+18	-12	+10	+2	+15	+2	+21	+2	+24	+11	+30	+11	+33	+20

d(mm)		n6		p5		p6		r6		r7		IT torance			
over	incl.	low	high	low	high	low	high	low	high	low	high	IT2	IT3	IT5	IT7
3	6	+16	+8	+17	+12	+20	+12	+23	+15	+27	+15	1.5	2.5	5	12
6	10	+19	+10	+21	+15	+24	+15	+28	+19	+34	+19	1.5	2.5	6	15
10	18	+23	+12	+26	+18	+29	+18	+34	+23	+41	+23	2	3	8	18
18	30	+28	+15	+31	+22	+35	+22	+41	+28	+49	+28	2.5	4	9	21
30	40	+33	+17	+37	+26	+42	+26	+50	+34	+59	+34	2.5	4	11	25
40	50	+39	+20	+45	+32	+51	+32	+60	+41	+71	+41	3	5	13	30

Dimensional tolerance for housing bore | Unit: μm

Diameter division D(mm)		E7		E10		E11		E12		F6		F7		F8	
over	incl.	low	high	low	high	low	high	low	high	low	high	low	high	low	high
3	6	+32	+20	+68	+20	+95	+20	+140	+20	+18	+10	+22	+10	+28	+10
6	10	+40	+25	+83	+25	+115	+25	+175	+25	+22	+13	+28	+13	+35	+13
10	18	+50	+32	+102	+32	+142	+32	+212	+32	+27	+16	+34	+16	+43	+16
18	30	+61	+40	+124	+40	+170	+40	+250	+40	+33	+20	+41	+20	+53	+20
30	40	+75	+50	+150	50	+210	+50	+300	+50	+41	+25	+50	+25	+64	+25
40	50	+90	+60	+180	+60	+250	+60	+360	+60	+49	+30	+60	+30	+76	+30
50	65	+90	+60	+180	+60	+250	+60	+360	+60	+49	+30	+60	+30	+76	+30
65	80	+90	+60	+180	+60	+250	+60	+360	+60	+49	+30	+60	+30	+76	+30
80	100	+107	+72	+212	+72	+292	+72	+422	+72	+58	+36	+71	+36	+90	+36
100	120	+107	+72	+212	+72	+292	+72	+422	+72	+58	+36	+71	+36	+90	+36
120	140	+125	+85	+245	+85	+335	+85	+485	+85	+68	+43	+83	+43	+106	+43

D(mm)		G6		G7		H6		H7		H8		H9		H10	
over	incl.	low	high	low	high	low	high	low	high	low	high	low	high	low	high
3	6	+12	+4	+16	+4	+8	0	+12	0	+18	0	+30	0	+48	0
6	10	+14	+5	+20	+5	+9	0	+15	0	+22	0	+36	0	+58	0
10	18	+17	+6	+24	+6	+11	0	+18	0	+27	0	+43	0	+70	0
18	30	+20	+7	+28	+7	+13	0	+21	0	+33	0	+52	0	+84	0
30	40	+25	+9	+34	+9	+16	0	+25	0	+39	0	+62	0	+100	0
40	50	+25	+9	+34	+9	+16	0	+25	0	+39	0	+62	0	+100	0
50	65	+29	+10	+40	+10	+19	0	+30	0	+46	0	+74	0	+120	0
65	80	+29	+10	+40	+10	+19	0	+30	0	+46	0	+74	0	+120	0
80	100	+34	+12	+47	+12	+22	0	+35	0	+54	0	+87	0	+140	0
100	120	+34	+12	+47	+12	+22	0	+35	0	+54	0	+87	0	+140	0
120	140	+39	+14	+54	+14	+25	0	+40	0	+63	0	+100	0	+160	0

D(mm)		H11		H13		J6		Js6		J7		Js7		K5	
over	incl.	low	high	low	high	low	high	low	high	low	high	low	high	low	high
3	6	+75	0	+180	0	+5	-3	+4	-4	+6	-6	+6	-6	0	-5
6	10	+90	0	+220	0	+5	-4	+4.5	-4.5	+8	-7	+7.5	-7.5	+1	-5
10	18	+110	0	+270	0	+6	-5	+5.5	-5.5	+10	-8	+9	-9	+2	-6
18	30	+130	0	+330	0	+8	-5	+6.5	-6.5	+12	-9	+10.5	-10.5	+1	-8
30	40	+160	0	+390	0	+10	-6	+8	-8	+14	-11	+12.5	-12.5	+2	-9
40	50	+160	0	+390	0	+10	-6	+8	-8	+14	-11	+12.5	-12.5	+2	-9
50	65	+190	0	+460	0	+13	-6	+9.5	-9.5	+18	-12	+15	-15	+3	-10
65	80	+190	0	+460	0	+13	-6	+9.5	-9.5	+18	-12	+15	-15	+3	-10
80	100	+220	0	+540	0	+16	-6	+11	-11	+22	-13	+17.5	-17.5	+2	-13
100	120	+220	0	+540	0	+16	-6	+11	-11	+22	-13	+17.5	-17.5	+2	-13
120	140	+250	0	+630	0	+18	-7	+12.5	-12.5	+26	-14	+20	-20	+3	-15

D(mm)		K6		K7		M6		M7		N6		N7		P6		P7	
over	incl.	low	high	low	high	low	high	low	high	low	high	low	high	low	high	low	high
3	6	+2	-6	+3	-9	-1	-13	0	-12	-5	0	-4	-16	-9	-17	-8	-20
6	10	+2	-7	+5	-10	-3	-16	0	-15	-7	0	-4	-19	-12	-21	-9	-24
10	18	+2	-9	+6	-12	-4	-20	0	-18	-9	0	-5	-23	-15	-26	-11	-29
18	30	+2	-11	+6	-15	-4	-24	0	-21	-11	0	-7	-28	-18	-31	-14	-35
30	40	+3	-13	+7	-18	-4	-28	0	-25	-12	0	-8	-33	-21	-37	-17	-42
40	50	+3	-13	+7	-18	-4	-28	0	-25	-12	0	-8	-33	-21	-37	-17	-42
50	65	+4	-15	+9	-21	-5	-33	0	-30	-14	0	-9	-39	-26	-45	-21	-51
65	80	+4	-15	+9	-21	-5	-33	0	-30	-14	0	-9	-39	-26	-45	-21	-51
80	100	+4	-18	+10	-25	-6	-38	0	-35	-16	0	-10	-45	-30	-52	-24	-59
100	120	+4	-18	+10	-25	-6	-38	0	-35	-16	0	-10	-45	-30	-52	-24	-59
120	140	+4	-21	+12	-28	-8	-45	0	-40	-20	0	-12	-52	-36	-61	-28	-68

<1> Inner rings | Unit: μm

Nominal bore diameter d (mm)		Single plane mean bore diameter deviation Δ_{dmp}								Mean single plane bore diameter variation V_{dmp}			
over	incl.	class 0		class 6		class 5		class 4 ¹⁾		class 0	class 6	class 5	class 4
		high	low	high	low	high	low	high	low				
0.6 ⁴⁾	2.5	0	-8	0	-7	0	-5	0	-4	6	5	3	2
2.5	10	0	-8	0	-7	0	-5	0	-4	6	5	3	2
10	18	0	-8	0	-7	0	-5	0	-4	6	5	3	2
18	30	0	-10	0	-8	0	-6	0	-5	8	6	3	2.5
30	50	0	-12	0	-10	0	-8	0	-6	9	8	4	3
50	80	0	-15	0	-12	0	-9	0	-7	11	9	5	3.5

d (mm)		Single radial plane bore diameter deviation V_{dp}											
over	incl.	diameter series 7, 8, 9				diameter series 0, 1				diameter series 2, 3, 4			
		class 0	class 6	class 5	class 4	class 0	class 6	class 5	class 4	class 0	class 6	class 5	class 4
0.6 ⁴⁾	2.5	10	9	5	4	8	7	4	3	6	5	4	3
2.5	10	10	9	5	4	8	7	4	3	6	5	4	3
10	18	10	9	5	4	8	7	4	3	6	5	4	3
18	30	13	10	6	5	10	8	5	4	8	6	5	4
30	50	15	13	8	6	12	10	6	5	9	8	6	5
50	80	19	15	9	7	19	15	7	5	11	9	7	5

d (mm)		Inner ring radial runout K_{ia}				Inner ring width deviation Δ_{Bs}							
over	incl.	class 0	class 6	class 5	class 4	normal				modified ³⁾			
		class 0	class 6	class 5	class 4	class 0	class 6	class 5	class 4	class 0	class 6	class 5	class 4
0.6 ⁴⁾	2.5	10	5	4	2.5	0	-40	0	-40	-	-	0	-250
2.5	10	10	6	4	2.5	0	-120	0	-40	0	-250	0	-250
10	18	10	7	4	2.5	0	-120	0	-80	0	-250	0	-250
18	30	13	8	4	3	0	-120	0	-120	0	-250	0	-250
30	50	15	10	5	4	0	-120	0	-120	0	-250	0	-250
50	80	20	10	5	4	0	-150	0	-150	0	-380	0	-250

d (mm)		Face runout with bore S_d		Inner ring axial runout ²⁾ S_{ia}		Inner ring width variation V_{Bs}				
over	incl.	class 5	class 4	class 5	class 4	class 0	class 6	class 5	class 4	class 2
0.6 ⁴⁾	2.5	7	3	7	3	12	12	5	2.5	1.5
2.5	10	7	3	7	3	15	15	5	2.5	1.5
10	18	7	3	7	3	20	20	5	2.5	1.5
18	30	8	4	8	4	20	20	5	2.5	1.5
30	50	8	4	8	4	20	20	5	3	1.5
50	80	8	5	8	5	25	25	6	4	1.5

1) To be applied for deep groove ball bearing and angular contact ball bearings.
 2) To be applied for individual raceway rings manufactured for combined bearing use.
 3) Nominal bore diameter of bearings of 0.6 mm is included in this dimensional division.

<2> Outer rings | Unit: μm

Nominal outside diameter D (mm)		Single plane mean outside diameter deviation Δ_{Dmp}								Single radial plane outside diameter variation V_{Dp} ⁶⁾	
over	incl.	class 0		class 6		class 5		class 4 ⁵⁾		capped bearings diameter series 2, 3, 4	
		high	low	high	low	high	low	high	low	class 0	class 6
2.5 ⁸⁾	6	0	-8	0	-7	0	-5	0	-4	10	9
6	18	0	-8	0	-7	0	-5	0	-4	10	9
18	30	0	-9	0	-8	0	-6	0	-5	12	10
30	50	0	-11	0	-9	0	-7	0	-6	16	13
50	80	0	-13	0	-11	0	-9	0	-7	20	16
80	120	0	-15	0	-13	0	-10	0	-8	26	20
120	150	0	-18	0	-15	0	-11	0	-9	30	25

D (mm)		Single radial plane outside diameter variation V_{Dp}											
over	incl.	diameter series 7, 8, 9				diameter series 0, 1				diameter series 2, 3, 4			
		class 0	class 6	class 5	class 4	class 0	class 6	class 5	class 4	class 0	class 6	class 5	class 4
2.5 ⁸⁾	6	10	9	5	4	8	7	4	3	6	5	4	3
6	18	10	9	5	4	8	7	4	3	6	5	4	3
18	30	12	10	6	5	9	8	5	4	7	6	5	4
30	50	14	11	7	6	11	9	5	5	8	7	5	5
50	80	16	14	9	7	13	11	7	5	10	8	7	5
80	120	19	16	10	8	19	16	8	6	11	10	8	6
120	150	23	19	11	9	23	19	8	7	14	11	8	7

D (mm)		Mean single plane outside diameter variation V_{Dmp}				Outer ring radial runout K_{ea}				Outside surface inclination S_D	
over	incl.	class 0	class 6	class 5	class 4	class 0	class 6	class 5	class 4	class 5	class 4
2.5 ⁸⁾	6	6	5	3	2	15	8	5	3	8	4
6	18	6	5	3	2	15	8	5	3	8	4
18	30	7	6	3	2.5	15	9	6	4	8	4
30	50	8	7	4	3	20	10	7	5	8	4
50	80	10	8	5	3.5	25	13	8	5	8	4
80	120	11	10	5	4	35	18	10	6	9	5
120	150	14	11	6	5	40	20	11	7	10	5

D (mm)		Outside ring axial runout S_{ea} ⁷⁾		Outer ring width deviation Δ_{Cs}		Outer ring width variation V_{Cs}					
over	incl.	class 5	class 4	all types		class 0	class 6	class 5	class 4		
2.5 ⁸⁾	6	8	5	Identical to Δ_{Bs} of inner ring of same bearing		Identical to Δ_{Bs} and V_{Bs} of inner ring of same bearing					
6	18	8	5							5	2.5
18	30	8	5							5	2.5
30	50	8	5							5	2.5
50	80	10	5							6	3
80	120	11	6							8	4
120	150	13	7	8	5						

4) To be applied in case snap rings are not installed on the bearings.
 5) To be applied for deep groove ball bearings and angular contact ball bearings.
 6) Nominal outer diameter of bearings of 2.5 mm is included in this dimensional division.

<1> Inner rings | Unit: µm

Nominal bore diameter d (mm)		Single plane mean bore diameter deviation Δ_{dmp}						Mean bore diameter variation V_{dmp}		
over	incl.	class 5		class 4		class 2		class 5	class 4 max	class 2
		high	low	high	low	high	low			
2.5	10	0	-5	0	-4	0	-2.5	3	2	1.5
10	18	0	-5	0	-4	0	-2.5	3	2	1.5
18	30	0	-6	0	-5	0	-2.5	3	2.5	1.5
30	50	0	-8	0	-6	0	-2.5	4	3	1.5
50	80	0	-9	0	-7	0	-4	5	3.5	2
80	120	0	-10	0	-8	0	-5	5	4	2.5
120	150	0	-13	0	-10	0	-7	7	5	3.5
150	180	0	-13	0	-10	0	-7	7	5	3.5
180	250	0	-15	0	-12	0	-8	8	6	4

d (mm)		Single radial plane bore diameter variation V_{dp}						Inner ring radial runout K_{ia}			Face runout with bore S_d		
over	incl.	Diameter series 9			Diameter series 0.2			class 5	class 4 max	class 2	class 5	class 4 max	class 2
		class 5	class 4 max	class 2	class 5	class 4 max	class 2						
2.5	10	5	4	2.5	4	3	2.5	4	2.5	1.5	7	3	1.5
10	18	5	4	2.5	4	3	2.5	4	2.5	1.5	7	3	1.5
18	30	6	5	2.5	5	4	2.5	4	3	2.5	8	4	1.5
30	50	8	6	2.5	6	5	2.5	5	4	2.5	8	4	1.5
50	80	9	7	4	7	5	4	5	4	2.5	8	5	1.5
80	120	10	8	5	8	6	5	6	5	2.5	9	5	2.5
120	150	13	10	7	10	8	7	8	6	2.5	10	6	2.5
150	180	13	10	7	10	8	7	8	6	5	10	6	4
180	250	15	12	8	12	9	8	10	8	5	11	7	5

d (mm)		Axial runout S_{ia}			Width deviation Δ_{Bs}						Width variation V_{Bs}		
over	incl.	class 5	class 4 max	class 2	Single bearing			Duplex bearing		class 5	class 4	class 2	
					class 5 high	class 4 low	class 2 high	low	class 5 high	class 4 low			
2.5	10	7	3	1.5	0	-40	0	-40	0	-250	5	2.5	1.5
10	18	7	3	1.5	0	-80	0	-80	0	-250	5	2.5	1.5
18	30	8	4	2.5	0	-120	0	-120	0	-250	5	2.5	1.5
30	50	8	4	2.5	0	-120	0	-120	0	-250	5	3	1.5
50	80	8	5	2.5	0	-150	0	-150	0	-250	6	4	1.5
80	120	9	5	2.5	0	-200	0	-200	0	-380	7	4	2.5
120	150	10	7	2.5	0	-250	0	-250	0	-380	8	5	2.5
150	180	10	7	5	0	-250	0	-250	0	-380	8	5	4
180	250	13	8	5	0	-300	0	-300	0	-500	10	6	5

<2> Outer rings | Unit: µm

Nominal outside diameter D (mm)		Single plane mean outside diameter deviation Δ_{Dmp}						Mean single plane outside diameter variation V_{Dmp}		
over	incl.	class 5		class 4		class 2		class 5	class 4 max	class 2
		high	low	high	low	high	low			
18	30	0	-6	0	-5	0	-4	3	2.5	2
30	50	0	-7	0	-6	0	-4	4	3	2
50	80	0	-9	0	-7	0	-4	5	3.5	2
80	120	0	-10	0	-8	0	-5	5	4	2.5
120	150	0	-11	0	-9	0	-5	6	5	2.5
150	180	0	-13	0	-10	0	-7	7	5	3.5
180	250	0	-15	0	-11	0	-8	8	6	4
250	315	0	-18	0	-13	0	-8	9	7	4

D (mm)		Single radial plane outside diameter variation V_{Dp}						Outer ring radial runout K_{ea}		
over	incl.	Diameter series 9			Diameter series 0.2			class 5	class 4 max	class 2
		class 5	class 4 max	class 2	class 5	class 4 max	class 2			
18	30	6	5	4	5	4	4	6	4	2.5
30	50	7	6	4	5	5	4	7	5	2.5
50	80	9	7	4	7	5	4	8	5	4
80	120	10	8	5	8	6	5	10	6	5
120	150	11	9	5	8	7	5	11	7	5
150	180	13	10	7	10	8	7	13	8	5
180	250	15	11	8	11	8	8	15	10	7
250	315	18	13	8	14	10	8	18	11	7

D (mm)		Outside surface inclination S_D			Axial runout S_{ea}			Width deviation Δ_{Cs}	Width variation V_{Cs}		
over	incl.	class 5	class 4 max	class 2	class 5	class 4 max	class 2	All types	class 5	class 4 max	class 2
								Identical to of Δ_{Bs} relative to d of the same bearing			
18	30	8	4	1.5	8	5	2.5		5	2.5	1.5
30	50	8	4	1.5	8	5	2.5		5	2.5	1.5
50	80	8	4	1.5	10	5	4		6	3	1.5
80	120	9	5	2.5	11	6	5		8	4	2.5
120	150	10	5	2.5	13	7	5		8	5	2.5
150	180	10	5	2.5	14	8	5		8	5	2.5
180	250	11	7	4	15	10	7		10	7	4
250	315	13	8	5	18	10	7		11	7	5

<1> Inner rings | Unit: μm

Nominal bore diameter $d(\text{mm})$		Single plane mean bore diameter deviation Δ_{dmp}						Mean bore diameter variation V_{dmp}		
over	incl.	class 5		class 4		class 2		class 5	class 4 max	class 2
		high	low	high	low	high	low			
18	30	0	-6	0	-5	0	-2.5	3	2.5	1.5
30	50	0	-8	0	-6	0	-2.5	4	3	1.5
50	80	0	-9	0	-7	0	-4	5	3.5	2
80	120	0	-10	0	-8	0	-5	5	4	2.5
120	150	0	-13	0	-10	0	-7	7	5	3.5
150	180	0	-13	0	-10	0	-7	7	5	3.5
180	250	0	-15	0	-12	0	-8	8	6	4
250	315	0	-18	-	-	-	-	9	-	-
315	400	0	-23	-	-	-	-	12	-	-
400	500	-	-	-	-	-	-	-	-	-

$d(\text{mm})$		Single radial plane bore diameter variation V_{dp}						Inner ring radial runout K_{ia}		
over	incl.	Diameter series 9			Diameter series 0			class 5	class 4 max	class 2
		class 5	class 4 max	class 2	class 5	class 4 max	class 2			
18	30	6	5	2.5	5	4	2.5	4	3	2.5
30	50	8	6	2.5	6	5	2.5	5	4	2.5
50	80	9	7	4	7	5	4	5	4	2.5
80	120	10	8	5	8	6	5	6	5	2.5
120	150	13	10	7	10	8	7	8	6	2.5
150	180	13	10	7	10	8	7	8	6	5
180	250	15	12	8	12	9	8	10	8	5
250	315	18	-	-	14	-	-	13	-	-
315	400	23	-	-	18	-	-	15	-	-
400	500	-	-	-	-	-	-	-	-	-

$d(\text{mm})$		Face runout with bore S_d			Width deviation Δ_{Bs}				Width variation V_{Bs}		
over	incl.	class 5	class 4 max	class 2	Single bearing				class 5	class 4 max	class 2
					class 5 high	class 4 low	class 2 high	class 2 low			
18	30	8	4	1.5	0	-120	0	-120	5	2.5	1.5
30	50	8	4	1.5	0	-120	0	-120	5	3	1.5
50	80	8	5	1.5	0	-150	0	-150	6	4	1.5
80	120	9	5	1.5	0	-200	0	-200	7	4	2.5
120	150	10	6	2.5	0	-250	0	-250	8	5	2.5
150	180	10	6	4	0	-250	0	-300	8	5	4
180	250	10	7	5	0	-300	0	-350	10	6	5
250	315	13	-	-	0	-350	-	-	13	-	-
315	400	15	-	-	0	-400	-	-	15	-	-
400	500	-	-	-	0	-	-	-	-	-	-

<2> Outer rings | Unit: μm

Nominal outside diameter $D(\text{mm})$		Single plane mean outside diameter deviation Δ_{Dmp}						Mean single plane outside diameter variation V_{Dmp}		
over	incl.	class 5		class 4		class 2		class 5	class 4 max	class 2
		high	low	high	low	high	low			
30	50	0	-7	0	-6	0	-4	4	3	2
50	80	0	-9	0	-7	0	-4	5	3.5	2
80	120	0	-10	0	-8	0	-5	5	4	2.5
120	150	0	-11	0	-9	0	-5	6	5	2.5
150	180	0	-13	0	-10	0	-7	7	5	3.5
180	250	0	-15	0	-11	0	-8	8	6	4
250	315	0	-18	0	-13	0	-8	9	7	4
315	400	0	-20	0	-15	0	-10	10	8	5
400	500	0	-23	-	-	-	-	12	-	-
500	630	0	-28	-	-	-	-	14	-	-
630	800	0	-35	-	-	-	-	18	-	-

$D(\text{mm})$		Single radial plane outside diameter variation V_{Dp}						Outer ring radial runout K_{ea}		
over	incl.	Diameter series 9			Diameter series 0			class 5	class 4 max	class 2
		class 5	class 4 max	class 2	class 5	class 4 max	class 2			
30	50	7	6	4	5	5	4	7	5	2.5
50	80	9	7	4	7	5	4	8	5	4
80	120	10	8	5	8	6	5	10	6	5
120	150	11	9	5	8	7	5	11	7	5
150	180	13	10	7	10	8	7	13	8	5
180	250	15	11	8	11	8	8	15	10	7
250	315	18	13	8	14	10	8	18	11	7
315	400	20	15	10	15	11	10	20	13	8
400	500	23	-	-	17	-	-	23	-	-
500	630	28	-	-	21	-	-	25	-	-
630	800	35	-	-	26	-	-	30	-	-

$D(\text{mm})$		Outer ring radial runout K_{ea}			Outside surface inclination S_D			Width deviation Δ_{Cs}	Width variation V_{Cs}		
over	incl.	class 5	class 4 max	class 2	class 5	class 4 max	class 2	All Classes	class 5	class 4 max	class 2
30	50	7	5	2.5	8	4	1.5	Identical to Δ_{Bs} relative to d of the same bearing	5	2.5	1.5
50	80	8	5	4	8	4	1.5		6	3	1.5
80	120	10	6	5	9	5	2.5		8	4	2.5
120	150	11	7	5	10	5	2.5		8	4	2.5
150	180	13	8	5	10	5	2.5		8	5	2.5
180	250	15	10	7	11	7	4		10	7	4
250	315	18	11	7	13	8	5		11	7	5
315	400	20	13	8	13	10	7		13	8	7
400	500	23	-	-	15	-	-		15	-	-
500	630	25	-	-	18	-	-		18	-	-
630	800	30	-	-	20	-	-		20	-	-

Our products

TPI Bearings are applied in a wide range of industries, including but not limited to two-wheelers, automotive, motor, machine tool segments. Besides ball bearings, we also offer fluid dynamic bearings, which are used in 3C industry.

Our services

TPI has cooperated with many top brands for a long time since all of them have satisfied our quality of bearings. Our company offers high-quality products and comprehensive solutions for customer success.

Our bearing test center offers investigation services to deal with clients application challenges. In addition to standard bearing types, customized bearings are also available to fulfill clients special requirements.

Furthermore, we are also available on request bearing accessories, including cages, shields, steel balls and rivets.

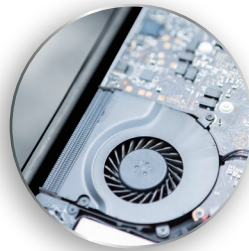

Industry
Applications



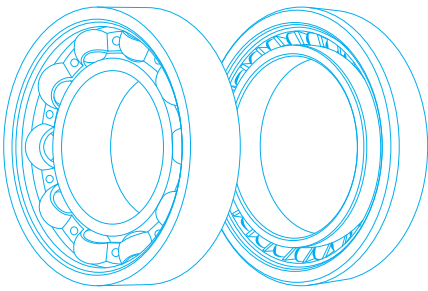

ROLLING BEARINGS

TPI[®]
BEARINGS

TUNG PEI INDUSTRIAL CO.. LTD.

Taipei Head Office

10F., No. 142, Sec. 4, Zhongxiao E. Rd., Taipei City 106, Taiwan

TEL +886-2-2741-7321 FAX +886-2-2741-6623

SHANGHAI TUNGPEI ENTERPRISE CO.. LTD.

Shanghai Plant

No.1555, Rongle Rd.(E), Songjiang Industrial Zone, Shanghai, China

TEL +86-21-5774-4698 FAX +86-21-5774-4695

PT. TPI MANUFACTURING INDONESIA

Indonesia Plant

Kawasan GIIC Blok AB No. 02, Kota Delta Mas, Desa Sukamahi Cikarang Pusat,

Bekasi 17530, Jawa Barat, Indonesia TEL +62-21-8067-7410

Although care has been taken to assure the accuracy of the data compiled in this catalog, TPI does not assume any liability to any company or person for errors or omissions.

www.tpi.tw



ISO 9001
ISO 14001
ISO 50001
ISO 45001